

1991 IEEE MTT-S International Microwave Symposium



by Peter Staecker
Chairman
1991 IEEE MTT-S
IMS Steering
Committee

As of the completion of the Technical Program Committee meeting in January, two encouraging data points suggest that this year's MTT Symposium is (again) a *don't miss* event. First, the exposition appears to be (as it has for a number of months) a sold-out situation. Second, the number of submitted technical papers has topped the 700 mark, an increase of almost 30% in only one year, and a guarantee of technical excellence. The following contains highlights of the Symposium which are developed in greater detail in the articles below.

Note that for your convenience this year, we are including registration forms for both the Technical Program and Symposium Housing in this copy of the *MTT Newsletter*.

The Technical Program

The weekend of January 12-13 completed a strenuous month's effort by all members of the Technical Program Committee. The results:

- 14 Workshops this year—guaranteed to pique your interest in at least one of your technical specialties.
- Two panel sessions per day Tuesday through Thursday, to keep the technical exchange going through the lunch hour.
- An Open Forum of 52 presentations in two sessions, featuring an invited speaker introducing each session with a tutorial paper of topical interest.
- A Student Papers Competition based on strong interest (34 student papers submitted).
- 5 Special Sessions (in addition to the Student Papers Competition) featuring focus again this year on lightwave and microwave-optical interactions, as well as three sessions linked to the MIT Radiation Laboratory.
- 3 invited papers from the European microwave community, focussing on commercial applications of microwaves.



Minuteman statue on the green in Lexington Center.

The Social Program

Guest tours in and around Boston start Tuesday morning. There will be no evening technical sessions at the MTT Symposium, so the evenings are yours to enjoy the city, or evening events planned for your entertainment. The *Microwave Journal* Reception, MTT Evening at Pops, the Industry Reception, the Awards Banquet; there's entertainment for all. (Reserve quickly for Evening at Pops—see details in the article below.)

(IMS Highlights continued on page 9)

Table of Contents

The 1991 IEEE MTT-S	
International Microwave Symposium	1
Technical Program	4
Local Arrangements	5
Workshops	6
Panel Sessions	7
Special Sessions	7
Guest Program	8
Open Forum	10
MIT Radiation Laboratory History Highlighted	10
Schedule of Events	18
Editor's Comments	2
Outgoing President's Message	3
Incoming President's Message	3
Call for Nominations: AdCom	11
Winter MTT-S AdCom Meeting Highlights	12
TAB Highlights	12
1991 MTT-S Awards	13
How We Handle Papers at the MTT	14
"ABQ in 92"	24
MTT-S Historical Collection	25
Viewpoints	26
IEEE Division IV Director's Report	27
ARFTG Highlights	28
Review of the 3rd Asia-Pacific Microwave Conference	29
Energy and Aerospace R&D Policy Committee	30
MTT-S Chapter Meetings	30
Call for Nominations for 1992 MTT-S Awards	33
Announcements and Calls for Papers	34

MTT-S Newsletter Staff

Editor: John Wassel

Associate Editor: David Zimmerman

Feature Articles Editor: John Eisenberg

Region 8 Editor: Rolf Jansen

Addresses listed in 1991 MTT-S Committee Directory

Editor's Comments

by John Wassel

With this issue, I plan to resume the normal publication schedule of three issues per year. This means that the *MTT-S Newsletter* should be delivered to the U.S.A. members about two months after the AdCom meetings and slightly longer for those in foreign countries depending upon the mailing situations. I appreciate the support of Al Estes, Gary Lerude, and Pat Walker of the *IEEE Newsletter* staff in helping me effect the transition to Editor.

Our content is slightly altered to reflect the changed format of the AdCom meeting which Dan Swanson discusses in his report. The new AdCom meeting format is structured to cover certain items in more depth and I expect the articles submitted will, in time, reflect the new emphasis. Also, John Eisenberg, our Special Features Editor, and I are planning to focus more upon the Technical Committees in the future. The Technical Committees are the foundation of our society and the work of these committees really defines the scope of our microwave technology. I hope that we can publicize their work by having at least two Committee reports in each issue. Since we have 18 committees (as listed in the directory) and three issues a year, it appears that we will have, on the average, one report from each Technical Committee about

(continued on back cover)

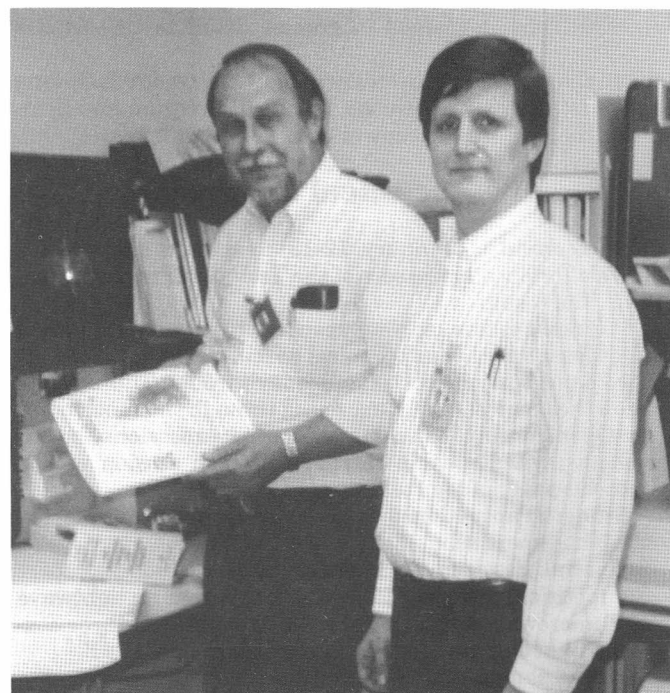

John Wassel and David Zimmerman preparing this issue.

Outgoing President's Message



by *Tatsuo Itoh*
1990 MTT-S President

I am leaving the office of the MTT President after a very rewarding experience. During my tenure, I tried to emphasize technical programs, information dissemination, and transnational activities. All of these items are actually inter-related. My desire was that the MTT-S become a truly transnational technical society, looking after emerging technology while maintaining preeminence as a leader of microwave technologies. It is coincidental that the economic and technological changes took place during my tenure which have made these issues even more essential for the future health of the society and microwave community. Vitality of the society is maintained only through constant search for new topics and new avenues for research, development, production, and engineering.

In response to quick dissemination of technical information, the new IEEE Microwave and Guided Wave Letters (MGWL) has been initiated. The journal has received enthusiastic support from AdCom and many technical leaders throughout the world. I am sure that this MGWL is useful and loved by all MTT members and others concerned with microwave and related technologies.

In connection with the emerging technology, we need to understand that the Society's health depends on the technologies it captures. Hence, it is everyone's business to be sensitive to emerging technologies. However, the Technical Committee structures of the MTT must play the leading role. We need to make the best use of Emerging Technology Workshop implemented during my tenure. Changing economic and social scene needs to be taken into consideration.

In regard to the transnational activities, I am happy to report that MTT-S is a leader among all the IEEE Societies. We have responded very quickly to a number of issues related to Eastern Europe. The first Region 10 Chapter Chairmen's meeting took place during the 3rd Asia Pacific Microwave Conference in Tokyo. We have witnessed establishment of many foreign chapters. During my tenure, I personally visited many foreign chapters. I asked the AdCom to have increased participation of foreign members in society activities. Specifically, I asked that Technical Committees increase participation by foreign members. This request received a positive response from a number of Technical Committees.

As I am leaving the President's office, I would like to provide the following suggestions for consideration by AdCom. In recent years, the number of microwave conferences and workshops increased drastically throughout the world. Many of them request MTT cooperative sponsorship. I believe that MTT should encourage topical meetings rather than mini-MTT symposia. Topical meetings are an excellent way to capture emerging technology. By nature, they are smaller in size and hence can be held in various places in the world. In

(continued on page 11)

Incoming President's Message



by *Ferdo Ivanek*
1991 MTT-S President

I would first like to thank the outgoing President, Tatsuo Itoh, for his personal accomplishments and for the accomplishments of his team. It will be a real challenge to match them!

I am pleased to present our 1991 team listed in the attached Directory, which includes the newly elected AdCom members and new chairpersons for most committees. I am thankful to all of them for having accepted their challenging appointments.

In his Outgoing President's Message, Tatsuo Itoh has identified some of the major opportunities for MTT-S progress in 1991. We have presented and discussed our action plan at the January 14-15 AdCom meeting in Boston; please refer to the accompanying meeting highlights by Dan Swanson, AdCom Secretary.

Among major MTT-S activities I would like to single out our Technical Committees (TCs) for special mention in this message. As a group, they represent the backbone of our society. The TC membership includes the majority of the *Transactions* and *Letter Journal* reviewers, of the Technical Program Committee members, and of the current and past AdCom members.

We must continuously develop the TC activities and keep their focus on the emerging technologies. Mutual coordination is a powerful tool in this process which is the primary responsibility of the Technical Coordinating Committee Chairperson. Our recent initiatives in this area are already proving highly beneficial. You may recall the write-up by Jorg Raue on page 9 of the Number 126 issue (Winter/Spring 1990) of the MTT-S Newsletter. For follow-up please refer to Dan Swanson's AdCom highlights in this issue.

This year we are taking another major initiative meant to further strengthen our TCs. It consists in developing closer working relationships with the most closely related IEEE Societies. Since most IEEE Societies are multidisciplinary, there is extensive mutual overlap and complementarity; both are inevitably growing with the advance of technology.

Our society seems to be among the best IEEE examples in this respect. Of the eighteen MTT-S technical committees, seventeen are closely related to thirteen other IEEE Societies (e.g., MTT-2, Microwave Acoustics, and the IEEE Society on Ultrasonics, Ferroelectrics and Frequency Control). In such cases it appears to be in the best common interest to explore the various possibilities of cooperation.

Our TC members have spoken up in favor of such cooperation, and we know of other IEEE societies' similar interests. We therefore suggested to our TCs to take the initiative in developing mutually beneficial working relationships with their related IEEE Societies. This is considered to be a high-priority action item, and we expect to be in a position to give

(continued on page 10)

1991 MTT-S Symposium: Technical Program

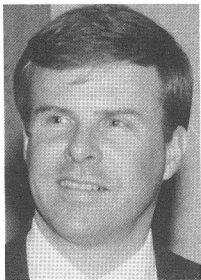

by Glenn Thoren
& Dan Masse
1991 TPC Chairmen



The Technical Program Committee for the 1991 MTT-S International Microwave Symposium met in Boston at the Westin Hotel to review the papers submitted and establish the technical program for the "Microwave Week." Despite the economic uncertainties and international tensions being felt by many, we expect the 1991 Symposium in Boston to continue the tradition of excellence it has shown in the past.

A record number of papers (over 700) were submitted for review by the Technical Program Committee. There were 349 papers submitted from the U.S., an increase of 46 over last year. A total of 346 papers were submitted from 34 foreign countries, an increase of 100 papers over last year. Two hundred and ninety-nine papers consisting of 126 long papers (20 minutes), 121 short papers (10 minutes) and 52 open forum papers were accepted. This is the largest number of papers ever presented at the MTT-S International Symposium.

1991 marks the fourth time that Boston will host this meeting since the formation of the MTT Society. Past years include 1959, 1967, 1983, and again we look forward to a record attendance, outstanding papers and many breakthroughs reported.

This year's meeting coincides with the 50th anniversary of the MIT Radiation Laboratory whose influence in establishing the microwave technology was fundamental. Ted Saad's accompanying article gives details of Rad Lab-related activities at the Symposium.



Sessions FF and JJ take shape under the guidance of Messrs. Ponlin, Cronson, Barn, and Pollard.

The 1991 MTT-S International Symposium will be held in the Hynes Convention Center in Copley Place. As usual, four parallel sessions are planned for each day of the meeting, from Tuesday, June 11, to Thursday, June 13, 1991. The Microwave and Millimeter Wave Monolithic Circuits Sympo-

sium will take place on Monday, June 10, and Tuesday, June 11, 1991. The Automatic RF Testing Group conference will be held in the afternoon of Thursday, June 13, and all day Friday, June 14, 1991.

Six Panel Sessions are planned, two for each day of the Symposium. Several special sessions are also being organized. Two Open Forum sessions will be held during the week, promising unique opportunities for interaction with the technical experts of your field. Details of these sessions are discussed in articles below.

Other innovations being tried this year include a student paper competition, which drew 34 submissions resulting in 9 finalists who can be heard in two sessions.

Finally, our invited speakers from the European microwave community this year will be presenting their papers in separate sessions so that they are grouped in areas of their interest. These speakers and their topics are:

- M. J. O'Mahony (British Telecom Research Labs, Martlesham Heath, UK), *Activities in the European Optical Communication Field*, Paper G-1.
- Ebbe Nyfors and Pertti Vainkainen (Helsinki University of Technology, Espoo, Finland), *Industrial Microwave Sensors*, Session FF-1.
- Heather Roe (Dept. of Electrical & Electronic Eng., Brunel University, Uxbridge, UK), *The use of Microwaves to Detect, Classify and Communicate with Road Vehicles*, Session KK-1.

June is a good time to visit New England. We hope you will come and join us in enjoying the MTT-S Symposium.

MTT Society Ombudsman



Ed Niehenke
Westinghouse Electric Corporation
P.O. Box 746, MS-75
Baltimore, MD 21203
(301) 765-4573
(301) 993-7432 (Fax)

I have been selected by the Microwave Theory and Techniques Society Administrative Committee (AdCom) to serve as your Ombudsman for 1991. The purpose of the Ombudsman is to receive complaints and assist members in solving problems encountered in obtaining membership services from IEEE and MTT-S.

My responsibilities include immediately acknowledging the member's complaint, investigating whatever action is necessary to rectify the problem, and responding to the member with details of the action taken and inviting the member to correspond further if either this action does not solve the problem or if the member still remains dissatisfied. I will provide a regular input to the *MTT-S Newsletter* concerning my activities as well as a year-end annual report to the MTT-S AdCom.

Please feel free to contact me by letter or telephone concerning your complaint. This action is another initiative of the MTT-S AdCom to provide total quality to the members.

1991 MTT-S Symposium: Local Arrangements

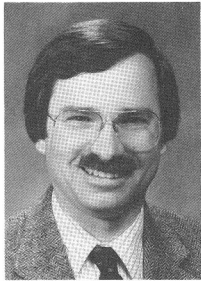

by John Putnam

Symposium Hotels

Room blocks have been reserved for conference attendees in fourteen Boston area hotels. Eight of the conference hotels, including the Westin and Marriott Co-Headquarters hotels, are a very short walk from the Hynes Convention Center. These hotels as well as the Convention Center are located in Boston's historic Back Bay area, renowned for elegant as well as informal restaurants and shopping areas, and within minutes of many of Boston's finest attractions.

The Best Western, Holiday Inn, Park Plaza, 57 Park Plaza, and Tremont House will be served by shuttle bus service during the week of the Symposium. The Hilton at Dedham Place is fifteen miles southeast of Boston, on Route 128. This hotel is about 25 to 30 minutes from downtown Boston and is accessible by a combination of commuter rail and "T" (subway) service. Hotel locations are shown on the Boston area map included on the conference housing form.

Hotel Registration

All hotel reservations will be handled by the Greater Boston Housing Bureau. The conference housing form must be used to make hotel reservations; please be sure to indicate three hotel preferences on the form. It is recommended that you respond early to ensure availability of your first choice.

Air Transportation

As the official carrier of the 1991 MTT Symposium, United Airlines is pleased to offer attendees a 45% discount off unrestricted United or United Express coach (Y/YN) fares, or a 5% discount off any United or United Express published fare in effect when tickets are purchased.

This special offer applies to travel on domestic segments of all United Airlines and United Express flights. Tickets must be purchased 7 days in advance. These fares are available through United's Meeting Plus Desk with all fare rules applying.

United Meeting Plus Specialists are on duty 7 days a week, 8:00 a.m. to 11:00 p.m. ET to make your reservations. The number is 1-800-521-4041 (United States and Canada). Please refer to meeting number 430 UP.

Mileage Plus members receive full credit for all miles flown.

Transportation From Logan International Airport

Getting from Logan International Airport to downtown Boston can be a challenge, especially during the morning and evening rush hours. Transportation between the airport and

the downtown hotels is most easily accomplished by taxi; taxi fare should run, depending on traffic conditions, between \$12 and \$15. The hotels do not, in general, operate shuttles to and from Logan Airport. Two independent shuttles do run, however, from each airport terminal to the hotels. These are as follows:

Shuttle	Phone Number	Fare
Airways Transportation	(617) 442-2700	\$6.50
City Transportation	(508) 376-8721	\$5.50

Airways Transportation runs every hour from 8:00 a.m. through 10:00 p.m., seven days a week. City Transportation runs from 6:15 a.m. to 9:15 p.m., every 30 minutes, seven days a week.

Subway service is available to the airport on the MBTA Blue Line, with a free MBTA shuttle bus connecting all terminals. For more detailed information about ground transportation to and from Logan, call 1-800-23-LOGAN.

Conference Transportation Services

Shuttle bus service will be provided from the Best Western, Holiday Inn, Park Plaza, 57 Park Plaza, and Tremont House to the Hynes Convention Center from Sunday afternoon, June 9, through Friday afternoon, June 14. The shuttles will run in the evening on Wednesday, June 12, to provide transportation to and from the Exhibitor's Cocktail Party and MTT Awards Banquet, both located in the Westin Hotel. Shuttle service will also be provided for those attending the Microwave Journal Cocktail Reception at the Boston Museum of Science in the evening on Monday, June 10, and the Rad Lab Reception at the Boston Pops on Tuesday, June 11.



John B. Hynes Veteran's Memorial Convention Center.

There will also be an "MTT Trolley" bus serving the Symposium. The MTT Trolleys are dedicated buses that will travel a specific route around the city, stopping at predetermined locations at arranged times. The trolleys will run all day long, from 9:00 a.m. to 4:00 p.m., stopping at their locations every hour or so. You can choose your city destination, do your thing for an hour or two (or three), then pick up the trolley when it makes its rounds again. Route-and-time maps will be available in the Hospitality Suite in the Westin Hotel and on the trolleys, and the trolleys will be obvious and well marked.

(continued on page 11)



1991 MTT-S Symposium: Workshops

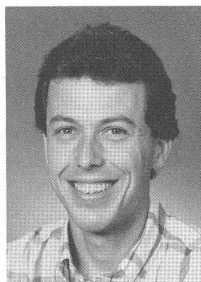

by Larry Kushner

One of the best things about the Boston area is the variety: four diverse seasons, mountains and oceans nearby, hundreds of colleges, city and country living, people from all over the world. So it's only appropriate that the 1991 Symposium Workshops offer a similar variety.

A total of fourteen workshops will be given: eleven full-day and three half-day. The topics span a broad spectrum from traditional microwave subjects like amplifiers and filters to some of the new emerging technologies such as microwave opto-electronics and superconductivity. We have tutorial workshops, advanced workshops, and workshops that have both components. There are workshops focusing on devices, circuits, systems, measurement, and education. Workshops run the gamut from very practical to very theoretical. Styles range from lecture-based to discussion-oriented. Applications range from low-volume state-of-the-art to high-volume consumer goods. Milliwatts to megawatts, UHF to light, com-

mercial to military to academic—you get the idea. This year's Symposium Workshops offer something for everyone.

Since the full Workshop Program appears elsewhere in this newsletter, I've just included a summary of the workshops below. All of the workshops have the endorsement of the appropriate MTT-S Technical Committees, and the organizers have enlisted an outstanding group of speakers, so I'm sure all of the workshops will be of high quality.

While having fourteen workshops makes it difficult to choose which one to attend, there is the benefit of reducing the audience size at each workshop, making them more conducive to interaction with the speakers and other participants. All full-day workshops include breakfast and lunch, while the half-day workshops include one meal. Besides filling your stomachs with some tasty food, lunches provide a good opportunity to meet other people with common interests in a less formal atmosphere.

Finally, most of the workshops will provide a set of printed notes and/or copies of viewgraphs. Where else can you attend lectures and have discussions with leaders in the field, receive a set of handouts, and get two meals all for \$65?

For more detailed information, see the Symposium Program (elsewhere in this newsletter), contact the workshop organizers, or give me a call at (617) 981-4195. See you at the Workshops.

MONDAY, JUNE 10	
TITLE	ORGANIZER(S)
Microwave Photonic Systems <i>(morning only)</i>	A. Seeds
Optical Probing of Microwave Circuits and Materials <i>(afternoon only)</i>	Chi H. Lee
Microwave Superconductivity Short Course <i>(morning only)</i>	S. Sridhar
UHF and Active Filter Technology New Packaging Techniques for MMICs and Discrete Devices	R. Bonetti, B. McAvoy B. Berson, F. Rosenbaum, R. Sparks, D. Maki
Loss, Cross-Talk and Package Effects in Microwave and Millimeter-Wave Integrated Circuits	I. Wolff, A. A. Oliner
Noise Concepts in Microwave Systems	K. Breuer
Amplifier Noise Measurements	D. Wait, G. Simpson
FRIDAY, JUNE 14	
TITLE	ORGANIZER(S)
Solid State Power Amplifier Efficiency, MMIC & MIC	F. Sullivan, G. Brehm, F. Ali, J. Kuno
GaAs MMIC System Insertion and Multifunction Chip Design: Issues and Trends	F. Ali, R. K. Gupta, R. Pengelly, I. Barhl
High Power Microwave Systems	J. Goel
Computer Applications in Electromagnetics Education	B. S. Perlman,
Design, Fabrication, and Packaging of High Temperature Superconducting Microwave Devices	M. F. Iskander M. Nisenoff
Spread Spectrum Technology in Consumer Electronics	S. S. Bharj

1991 MTT-S Symposium: Panel Sessions



by John Heaton
and David Meharry

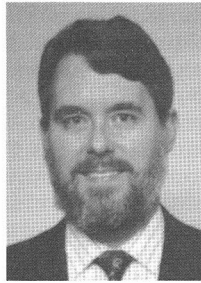

Panel sessions offer symposium attendees an opportunity to hear the often differing views of several experts on high interest topics. Audience participation is encouraged, and question and answer sessions often occupy the majority of the time allocation. Six panel sessions will be held during the 1991 IMS, all over the 12:00 to 1:30 mid-day break. Registration for these sessions will include a box lunch.

Controversial topics are featured in several of the panel sessions. The first session deals with the availability of standard commercial packages, and includes panelists representing domestic and foreign package manufacturers. Several of the panel discussions deal with the popular MMIC area, and address foundry fabrication, testing, and consumer applications from the user's point of view. Panelists representing major MMIC foundries will discuss the second sourcing issue, and the trade-off involved in selecting dc or rf on wafer testing, and a panel made up of users will discuss the current status of commercial MMICs from a user's perspective.

Two panel sessions deal with the design process. The first deals with the necessity for and availability of integrated CAD stations that support multiple tools, and features a

(continued on page 10)

TUESDAY, JUNE 11	
TITLE	ORGANIZER(S)
Packaging: Is There a Need for Domestic Suppliers?	B. Berson (415) 968-2182, F. Rosenbaum
GaAs MMICs for Consumer Applications	D. Maki (508) 453-3100, F. Ali
WEDNESDAY, JUNE 12	
TITLE	ORGANIZER(S)
GaAs MMIC Insertion: How Important Is Foundry Transportability of Designs?	F. Ali (408) 732-3413, G. Brehm, M. Kim
Concurrent Design Engineering for Electronic Design Automation	J. Goel (213) 814-2031, R. Goyal
THURSDAY, JUNE 13	
TITLE	ORGANIZER(S)
Is 100% RF-on-Wafer Testing Necessary for MMIC Production?	T. Miers (303) 460-2484
Microwave Hardware Description Language: What Is It? Why Do We Need It?	L. Carmichael (908) 532-0221

1991 MTT-S Symposium: Special Sessions



by John Heaton

The IMS often includes several special sessions that are selected to give in-depth coverage of high interest or new technology areas. Invited papers are featured in these sessions, although appropriate regularly submitted papers are also included.

Special sessions also are organized to highlight or commemorate memorable individuals and events in our profession. This year, the theme of our symposium is the 50th anniversary of the founding of the MIT Radiation Laboratory, and a special session to commemorate the Rad Lab is planned. This session will feature some of the original Rad Lab staff as invited speakers.

In this year's Symposium we are featuring four special sessions that deal with exciting new technology areas. Two sessions deal with lightwave technology. In the first, application of high power optical switching for generation of extremely short pulses is explored. Subsequent papers deal with system applications of ultra-wide band impulses and some of the unique design issues involved. The second session focuses on system and component design for lightwave transmission systems. In particular, application of microwave techniques to these systems is addressed.

A special session dealing with radiometers has been organized, and bridges the gap between the fundamental radiometer work performed at the Rad Lab to cover current capability and applications of radiometers. The session will feature an overview by R. H. Dicke, who invented the passive radiometer at the Rad Lab in 1946.

Our final special session focuses on microwaves in medicine and deals with application of radar ranging for the imaging of tissue. Various aspects of radar ranging including simulation, time and frequency domain measurements, and modulation will be considered.

The special sessions scheduled for the 1991 IMS are as follows:

TUESDAY, JUNE 11	
TITLE	ORGANIZER(S)
Rad Lab Session	T. Saad
High Power Optical Switching for Ultra Wide-Band Applications	A. Rosen
Multi-GHz Lightwave Transmission Systems	A. J. Seeds, P. R. Herzfeld
Microwave Radiometers	K. Tomiyasu, D. Staelin
WEDNESDAY, JUNE 12	
TITLE	ORGANIZER(S)
Time-Resolved Spectroscopy and Imaging of Tissue	B. Chance, R. Powell

1991 MTT-S Symposium: Guest Program



by Mikelle Carr
and Susan Staecker



Hello—o-o-o Boston!

With apologies to our celebrated Brahmin, a well-known wit once remarked about our fair city . . .

“Welcome, good friends, to Boston,
the home of the bean and the cod . . .

Where the Lodges speak only to the Cabots,
and the Cabots speak only to God!”

Beantown! Back Bay! Beacon Hill! The Freedom Trail . . .
Old North Church . . . The Minutemen . . . the USS *Constitution* . . .
Harvard University . . . The Kennedy Compound . . .
Old Cape Cod . . . The Nantucket Lighthouse . . . Filene’s
Basement! . . . Charlestown . . . Thoreau, Alcott, Emerson . . .

All of these are Boston, and all are here to see in this historical and exciting city, brimming with tradition and vitality—some very new, and much of it familiar and fused with ancestry. To quote from the excellent guidebook we have chosen for the Symposium, “This city has seen more from its bricked and cobbled hills than any other American city, and few European cities of its size can rival Boston’s rich political, social, and cultural heritage. It is a great city of firsts: the first public library in America, the first subway, the first college, and the first public school are all here. Boston is even responsible for the first lighthouse, and the first Christmas card ever produced in America.”

During your stay at the Symposium, you may wish to take some of the suggested tours with the guides of Uncommon Boston; or you can choose a map or two, ask some questions,

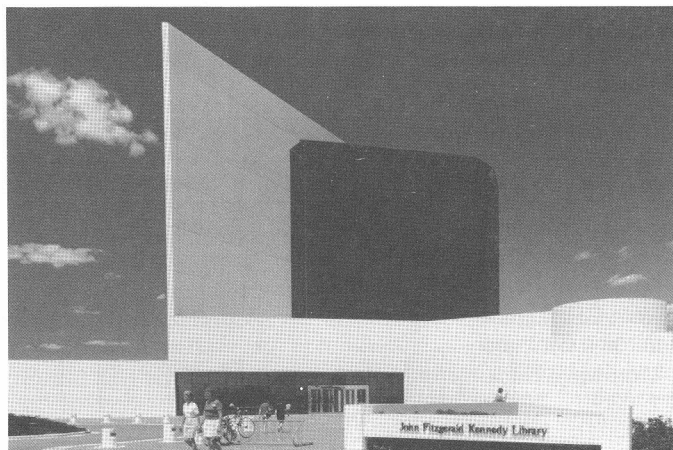

John F. Kennedy Library and Museum, the nation’s memorial to the 35th President of the United States and New England’s only presidential library.

and go blissfully off on your own to . . . the Aquarium (it’s colorful, huge, fun, and fabulous!); Fanueil Hall Marketplace and the mind-boggling array of munchies in its Food Emporium; The JFK Library—take some time to remember Camelot. You can try on discounted designer clothing in the famous aisles of Filene’s Basement (no dressing rooms); walk the painted red line of The Freedom Trail into a personal picture of history; or stroll along nineteenth century Newbury Street to a sidewalk cafe or an elegant gallery—the brownstones evoke a time-gone-by, with charming alleyways and miraculous, tiny gardens. Ride the “T” (our easy-to-get-around-on subway) to Harvard Square, and walk the hallowed paths of Harvard University. Stop by Nini’s Corner in the Square and browse through magazines and newspapers from ALL over the world, or stop and watch the street performers—from reggae to poetry . . . all of these are also Boston.

For those of you who like to grab a guidebook and take off on your own around the city, step on board the MTT Trolley. The MTT Trolleys are dedicated buses that will travel a specific route around the city, stopping at predetermined locations at arranged times. The trolleys will run all day long, from 9:00 a.m. to 4:00 p.m., stopping at their locations every hour or so. You can choose your city destination, hop on the bus, Gus—do your thing for an hour or two (or three), then pick up the trolley when it makes its rounds again. Route-

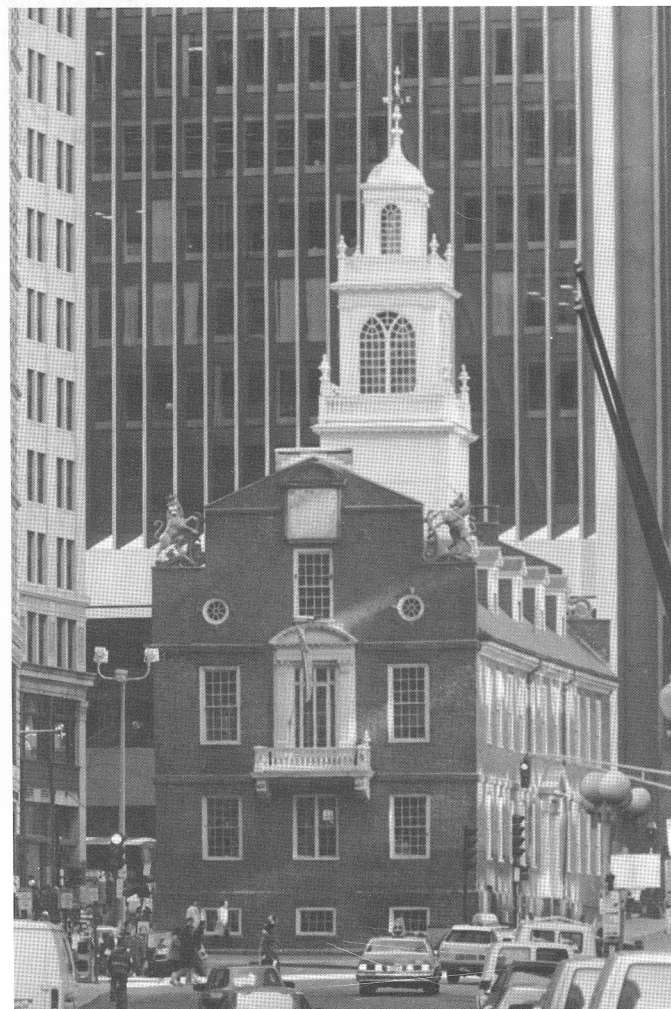

Old State House, Washington and State Street, built in 1712, seat of Colonial Government.

and-time maps will be available in the Hospitality Suite and on the trolleys, and the trolleys will be obvious and well marked.

For those of you who like to sit back and let your guide do the talking, we are offering four very different daytime tours, and one evening of pure enjoyment. The daytime tours all depart from the ground level motor entrance of the Westin Hotel, and we strongly recommend appropriate dress and COMFORTABLE walking shoes.

On Tuesday, June 11th, at the week's beginning, you may wish to participate in the WELCOME TO BOSTON mini-tour, touching on many of the sights that echo this historically rich and fascinating city. The tour will include the old and new in the stately Brahmin neighborhoods of Beacon Hill, the Victorian brownstones of Back Bay, and the exclusive boutiques and art galleries of Newbury Street. You'll also see the explosion of color and variety of Quincy Market (pronounced Quinsey), with its food emporiums, unique shops, and outdoor entertainment. This is a morning tour, and after it's over, you may wish to stay at Quincy Market for shopping and lunch on your own, or sign up for the planned seafood lunch at a local waterfront restaurant. The tour will return to the hotel before lunch, if you'd prefer to just relax and treat your tootsies.

On Wednesday, June 12th, beginning at 9:00 a.m., how about an all-day Shop-'till-You-Drop-major-manufacturers-discount-store spree in world-famous Kittery, Maine—lunch included? Every time any of us locals go up there, the number of stores has doubled, along with the name brands and bargains—and here's an attempt at rhyming to give you some spending ideas:

Waterford Crystal, J. Crew, Anne Klein, Bass Shoe.
Crate & Barrel, Osh Kosh B'Gosh, Joan & David, Villeroy & Bosch.

Hanes, Dansk, and Crazy Horse.
Ralph Lauren, and Eurosport.
Totes, Towle, and Timberland Shoe,
Liz Claiborne, Lenox, and Mikasa too.
Van Heusen, Hathaway, and J. G. Hook,
Oneida, Black & Decker, and Lauriat Book.

(et cetera, et cetera, et cetera . . .)

The third tour, also on Wednesday, June 12th, is especially designed for the history or literature lover. Beginning at 9:00 a.m., take a walk into time through Lexington and Concord. This nation's history fills the woods surrounding the two towns, and once away from the noise of the 90's, you can almost hear The Minutemen firing on the common, or see the Redcoats marching through the brush. You can wander through the Alcott home where Louisa May wrote her beloved *Little Women*; and you will sense the peace and beauty of these surroundings so beloved by Thoreau. This is a morning tour, and you'll have time for a cat-nap before the Symposium banquet in the evening.

On Thursday, June 13th, starting at 9:00 a.m., the fourth tour on our list is Rockport, a typical New England sea town, north of Boston on the coast. Rockport's claim to fame (among others) is Motif No. 1, the single most-often painted, sketched and photographed scene in the United States. The Motif is surrounded by Bearskin Neck, a charming maze of tiny shops, galleries, and restaurants lining a great stone jetty that protrudes arrogantly into the sea, inviting you to lunch on a rock or converse with the seabirds that sweep the water. After wandering in Rockport, you are invited to a late lunch-in-the-rough at Woodman's—your choice of fresh-caught lobster, clams, scallops, fish 'n chips (or chicken), and the best onion rings in the known world.

And then, of course, there's always the Boston Pops! We don't think any additional description is required—just that

the concert is on the evening of Tuesday, June 11th, beginning at 8:00 p.m., and ticket orders **MUST BE RECEIVED NO LATER THAN APRIL 30TH**. Two categories of seating are available at tables for four or five on the main floor of Symphony Hall, and light refreshments (wine, beer, soft drinks, cheese and crackers, sandwiches, fruit) may be ordered during the performance. Be sure to pre-register for these tickets—they will sell very quickly, and **WILL BE DISTRIBUTED ON A FIRST-COME, FIRST-SERVED BASIS!**

A guest Hospitality Suite will be located in the Staffordshire Room in the Westin Hotel. The Suite will open at 7:30 a.m., and remain open throughout the day until 5:00 p.m. A Continental breakfast will be served until late morning, with light snacks, soft drinks, and coffee and tea available during the day. The Suite will be staffed with guides from Uncommon Boston, as well as local residents, to distribute maps and guidebooks and answer any questions you may have.

IMS Highlights

(continued from page 1)

The Historical Exhibit

Serving also as the focal point of the MIT Radiation Laboratory Celebration, the Historical Exhibit will be situated in the center of activities in the Hynes Convention Center.

Local Arrangements

The article by John Putnam describes the basic transportation and housing issues of interest in and around Boston.

Air travel is a popular means of transportation, and we have made arrangements with United Airlines to get you to Boston from long distances away. If you are coming from New York, however, you may want to try Amtrak. Here are some comparisons (as of January, 1991) between the train and the Trump Shuttle:

Item	Amtrak	Trump Shuttle
Weekday fare (one way)	\$45	\$145
Travel time	3 hrs. 50 min.	2 hrs. 20 min.
Service	2/day	hourly
Noise	tie	tie
Food	better	
Computer outlet	yes	no
Easy access from city	yes	no
Comfortable seats	tie	tie
Legroom	better	

An interesting alternative. Don't forget, South Station in Boston is a pretty short taxicab ride from the Hynes, and a very short MBTA ride.

Detailed Description of Events in the Program

The full details of both the technical program and other events are available in the *Program*, which should be available on or about April 1. In addition, the details of the technical program will be electronically accessible this year. To use this service try either of the following addresses:

uunet!technet!mtt91

or

technet!mtt91@uunet.uu.net

1991 MTT-S Symposium: Open Forum



by Ross Hicks
and Geoff Dawe

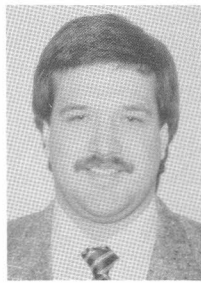

1991 MTT-S Symposium: MIT Radiation Laboratory History Highlighted



by Ted Saad

The organizers of the 1991 Open Forum invite you to stop by the Hynes for both sessions of the Forum. It was enjoyable putting together these sessions and this year's Forum should be particularly exciting. As you know, the Open Forum is a poster session in an informal setting where attendees and authors can interact directly. This year, however, we are offering several new features in an effort to "spice up" the event. The most prominent of these is the use of an invited speaker to kick-off each session. This year Steve Maas, the *MTT-S Transactions* Editor, and Mike Steer of NC State University will make a 15-minute presentation at the beginning of each of their respective sessions to get the ball rolling. Following the presentation, a brief synopsis of the Open Forum papers will be provided by the session chairman and then the booth areas will be open for normal operation. We hope the Open Forum invited speaker concept will catch on in future Symposiums; let's see how it works here in Boston.

In addition to the invited speakers, the Open Forum will be enhanced by limiting the number of papers accepted for each session to approximately twenty-five. This was done in an effort to increase the quality of the papers presented and to promote the Forum as having an equivalent standard to the regular presentations. Papers for the Open Forum have been reviewed twice, once by the appropriate TPC subcommittee and then by a special Open Forum Committee. Authors of accepted papers will be contacted by the Open Forum organizers and encouraged to exploit the Open Forum medium as much as possible in their presentation.

At the TPC meeting, we tried to group papers of similar topics together and to derive a theme or themes for each session. This way attendees will be able to compare and discuss varying viewpoints on similar subjects. Hopefully, no fights will break out over rival opinions! The success of this concept will depend on the subject matter of the accepted papers and the enthusiasm of the authors in giving their booth presentations.

The Open Forum gives attendees the best opportunity to interact with other workers in the fields that interest them. It is always a fun time to learn and socialize too. There will be plenty of wine, cheese and fruit and interesting people at each session. Hope to see you there!

Panel Sessions

(continued from page 7)

panel made up of users and representatives from tool and platform suppliers. The second panel addresses the high interest MHDL area, and will attempt to acquaint the microwave community with the MHDL concept and utility. The panel will be composed of users as well as representatives from the DoD Tri-Service MHDL Initiative.

The panel sessions and organizers are shown on page 7.

The focus of this year's MTT-S Symposium is the celebration of the 50th anniversary of the establishment of the MIT Radiation Laboratory. For many of us, the work done there and the subsequent publication of the invaluable 28-volume set of textbooks marked the beginnings of microwave technology as we know it today. To that effort and that special group of individuals we owe much.

To honor the occasion, we have planned a number of events. On Tuesday morning, June 11, the opening plenary-session, which will take place in the Hynes Auditorium, will feature a keynote speech by Dr. Norman F. Ramsey, Rad Lab alumnus, Nobel Prize winner, and IEEE Medal of Honor recipient. Following that session, there will be a special Rad Lab session. We have invited Nathan Marcovitz, Robert Pound and Ivan Getting to tell us about the work at the Lab and what followed.

In addition to the Rad Lab session, there will be a special session on microwave radiometers which will include historical references to the pioneering work done by Bob Dicke. Also, Britton Chance is organizing a special session on the use of time-resolved spectroscopy for the imaging of human tissue.

During the three days of the Symposium, Rad Lab alumni and their guests will be invited to visit the company exhibits and attend any of the technical sessions. In addition, in the Historical Exhibit area, there will be room for meeting and socializing. Rad Lab alumni should use it as a focal point throughout the Symposium.

Incoming President's Message

(continued from page 3)

a progress report later this year.

I solicit personal suggestions and initiatives from MTT-S members whose parallel activity in a related IEEE Society enables them to contribute toward this new goal. Please call or write to the corresponding TC Chairperson or to Eliot Cohen, Vice-Chairman of the Technical Coordinating Committee (TCC), who is leading this effort.

This is just one example of how MTT-S members can join other volunteers in helping our society to grow stronger and to better serve the membership. Do not hesitate to inquire about other possibilities within your area of interest, to make suggestions and to volunteer for MTT-S activities. You will discover that there is plenty of opportunity for constructive, satisfying contributions!

Local Arrangements

(continued from page 5)

Getting Around Boston

There are several means by which one can get around downtown Boston. Due to its small geographic size and numerous attractions, Boston is an excellent walking city. Taxi service within the city is easy to obtain and convenient. Taxicab stands are located throughout the city, or one can



Acorn Street on Beacon Hill.

hail a cab on the major streets. Taxis cost a minimum of \$1.50 plus \$.20 for each 1/7 mile thereafter, plus all toll fees, and an additional \$1.00 for cabs originating at Logan International Airport.

The Massachusetts Bay Transit Authority (MBTA), also known as the "T", provides cheap, fast service to just about anywhere in the city. The four main lines, known as the Blue, Green, Red, and Orange lines, cover the downtown area and different outlying neighborhoods. Fares range from \$.75 to \$1.50, depending on whether one changes from one of the four lines to another. The "T" starts running at 5:00 a.m. and the last trains leave the downtown area at 12:45 a.m. For more information about the "T" call (617) 722-3200.

Driving in Boston can be a confusing experience. Heavy traffic, narrow streets and unexpected one-ways are just a few of the surprises in store for visitors. If driving is necessary, it would be useful to get a detailed Boston street map before setting out. There are a number of public and private parking lots throughout the city; fees range from \$10.00 to \$15.00 per day. There is limited on-street parking with various posted restrictions.

Budget Rent-a-Car has been selected as the official car rental agency for the 1991 MTT-S Symposium. Rates offered by Budget for conferences attendees represent a substantial discount off of their normal rental rates. The number to call for reserving a car at the conference rate is 1-800-722-3773; use the keyword **IEEE-MTT** to identify yourself as an IEEE MTT-S IMS attendee.

Outgoing President's Message

(continued from page 3)

In addition, we should open a way in which the Technical Committees can sponsor the topical meetings. Such arrangements increase the chance of participation of foreign members in Technical Committees.

This past year has been one of my most rewarding years. I would like to continue to participate in various activities of the MTT-S. I thank you very much for support by AdCom and all members of MTT-S.

Call for Nominations: AdCom

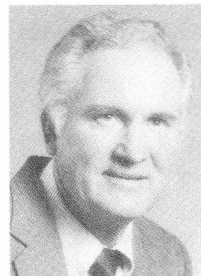

by John B. Horton, Chairman
Nominations Committee

Each year the MTT-S holds elections at the annual fall meeting to elect members to serve on the Administrative Committee (AdCom). The bylaws state that the Nominations Subcommittee will select a slate of at least two members of the Society for each vacancy in the elected membership, which will occur on the Administrative Committee the following January 1. The Nominations Subcommittee shall be guided in their selections by principles of efficiency, geographical, and organizational distribution. Administrative Committee members who have served three consecutive terms by the following January 1 shall not be considered eligible for nomination by the Nominations Subcommittee.

The bylaws provide three means by which one may be nominated for the Administrative Committee. They are as follows:

1. Nominations by the Nominations Subcommittee
2. Nomination by petition signed by 25 MTT-S members and submitted to the Nominations Chairman prior to September 1, 1991
3. Informal Chapter nominations.

The informal nominations by Chapters does not guarantee nomination. The Chapter Chairman should convey the informal nominations to the Nominations Chairman by September 1, 1991. Both nominees and potential nominees must be contacted prior to the fall annual meeting to ascertain that they will accept the nomination.

The Nominations Subcommittee consists of 8 Society members, half of whom are not current AdCom members as specified by the bylaws. A wide geographic distribution of the Nominations Subcommittee is designed to give a fair representation to all Chapters and members.

The geographical and affiliation distribution of current AdCom members is given below.

Present AdCom (1991): Total = 18			
Eastern U.S.	7	Industry	13
Central U.S.	2	Government	3
Western U.S.	7	University	2
Europe	2		

The Nominations Subcommittee needs your help in suggesting potential nominees to serve our membership as AdCom members. Please submit your suggestions to the Chairman of the Nominations Committee and/or your local Chapter Chairman. The schedule for the Nominations Subcommittee calls for providing a slate of candidates by September 1, 1991. Please keep in mind the potential nominees must be able to commit themselves to at least three meetings a year, held at various locations in the U.S. Nominate your prospective AdCom member today.

Winter MTT-S AdCom Meeting Highlights

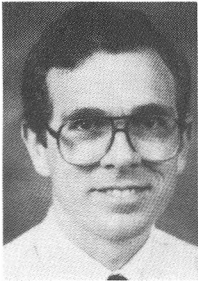

by Dan Swanson
MTT-S AdCom Secretary

The winter MTT-S AdCom meeting was held on January 14-15 at the Westin Hotel, Boston, Massachusetts. The AdCom is grateful to John Putnam for his excellent work on local arrangements for the meeting.

This was the first AdCom meeting held under the new Annual Agenda Framework. This new concept was developed after a survey of AdCom members indicated that our meetings could be more efficient. The new Annual Agenda Framework highlights several key priority items at each meeting while allowing time for brief reports from non-highlighted committees. Each major committee is highlighted at least once during the year. Our first meeting under this new system ran rather smoothly thanks to the cooperation and efforts of the major committee chairmen.

Our meeting began with an Outgoing President's Message from Tatsuo Itoh. Noteworthy accomplishments during 1990 included the development of the *Microwave and Guided Wave Letters Journal*, the organization of the Emerging Technologies Workshop, and the development of transnational activities within the MTT Society.

We then heard from incoming President, Ferdo Ivanek. Ferdo expressed his appreciation to Tatsuo and his team for their excellent work in 1990. He also thanked the major committee appointees for accepting their demanding assignments. Ferdo highlighted the Emerging Technologies Workshop, the Microwaves in Medicine Meeting, the *Microwave and Guided Wave Letters Journal*, and the formation of new chapters in Eastern Europe as examples of "Opportunities for Progress in 1991." Another group of "Start-up Opportunities" included a new membership drive, planning for "Microwave Week," expanded meeting sponsorships, and starting an educational survey.

The next item on the agenda was Finances. Bob Moore presented some recommended corrections to the existing 1991 budget which reflect our tougher economic times. These "belt-tightening" revisions to the budget were approved. Skip Bryan gave a presentation on planning for the 1992 budget. Skip is working on a direct connection to the IEEE for more timely financial data and software for the MTT-S budget and the Symposium budget preparation.

A major focus of this meeting was the 1991 MTT-S Symposium to be held in Boston in June. The Technical Program Committee met prior to the AdCom meeting and Glenn Thoren reported on their results. A record number of 695 papers were submitted, an increase of 149 over last year. From this large pool of excellent papers, 299 were accepted for presentation at the Symposium.

Peter Staacker, 1991 Steering Committee Chairman, then gave his report on plans for the Symposium. Changes to the

(continued on page 25)

TAB Highlights

by Ferdo Ivanek
1991 President

For the benefit of new members let me briefly state that the Technical Advisory Board (TAB) is the forum through which the 37 IEEE Societies conduct business of common interest. It meets 3 times a year. The Societies are represented by their Presidents. If you would like to have additional background information, please refer to the corresponding write-ups in the preceding two *MTT-S Newsletter* issues: pages 15-17 of Number 126 (Winter/Spring 1990), and pages 31-32 of Number 127 (Fall 1990).

The quoted background material is rather exhaustive. Therefore, I can simply provide follow-up information of broader interest to the membership, accompanied by a few comments. Chairpersons of major MTT-S Committees are on my distribution list for the "Summary of Actions Taken at TAB Meeting" and the "Technical Activities Newsbrief," which are produced by the TAB Secretariat. However, this material is available to other interested MTT-S members on request. (Please call or write to Dan Swanson, AdCom Secretary; he is listed in our 1991 Directory.)

It is of special significance to our Society that this was the first TAB meeting at which our Division IV was represented by the newly elected Director Martin Schneider, MTT-S AdCom member until the end of 1990, when he had to resign to take over his new IEEE position. This is an excellent opportunity for Martin, because his energy, dedication and inventiveness have surpassed the bounds of a single society.

We shall follow with interest Martin's new activities which will necessarily be broader and more demanding than those of his predecessor. This is the consequence of a divisional restructuring that transferred the Broadcast Technology Society and the Consumer Electronics Society from Division III to Division IV. (In addition to MTT-S, Division IV formerly included Antennas and Propagation, Electromagnetic Compatibility, Magnetics, Nuclear and Plasma Sciences, and the Superconductivity Committee.)

TAB is a complex organization that deals with many IEEE societal aspects. It is a real challenge for every incoming MTT-S President to truly understand what is going on and to act in the Society's best interest. At the same time, the TAB meetings offer excellent opportunities for comparing the MTT-S with other IEEE Societies, for learning from their experience, and for initiating cooperation.

One such initiative brought before the TAB President's Forum was the establishment of a Quality Engineering Council. It appealed to the majority, not surprisingly. An ad hoc committee has been formed to review the relevant issues in this matter. Twenty-one Societies are represented, including the MTT-S.

Several agenda items addressed financial matters. The most serious one seems to be the growing deficit of the IEEE General Fund, which is said to be caused by IEEE's long-term investment in the headquarters facilities in Piscataway, New Jersey. By contrast, the IEEE Societies are reported to be building up their cash reserves that keep accumulating from surplus-producing activities (conferences, symposia, etc.).

This imbalance stimulated the idea of a "G&A assessment" as a means of reversing the negative trend of the IEEE General Fund. Inconclusive discussions led to the abandonment of this idea in favor of achieving the same objective

(continued on page 16)

1991 MTT-S Awards



Fred Rosenbaum
Awards Committee
Co-Chairman



Louis Medgyesi-Mitschang
Awards Committee
Co-Chairman

The recipients of the 1991 major MTT-S Awards are listed below:

- **Microwave Career Award:** Sogo Okamura
"For meritorious achievement and outstanding technical contribution in the field of microwave theory and techniques."
- **Microwave Application Award:** Eric Strid and K. Reed Gleason
"For the development of microprobe technology, its application to on-wafer test of microwave semiconductor devices, and for innovative microwave measurement techniques."
- **Distinguished Service Award:** Charles T. Rucker
"For his outstanding and dedicated service to the Society."
- **Microwave Prize:** Masayoshi Aikawa, Tsuneo Tokumitsu, and Shinji Hara
"Very Small Ultra-Wide-Band MMIC Magic T and Applications to Combiners and Dividers," *IEEE Transactions on Microwave Theory and Techniques*, Vol. 37, pp. 1985-1990, December 1989.
- **Pioneer Award:** Robert H. Dicke
"For the invention of the microwave radiometer."
The work was documented in the paper: R. H. Dicke, "The Measurement of Thermal Radiation at Microwave Frequencies," *Review of Scientific Instruments*, Vol. 17, pp. 268-275, July 1946.
- **N. Walter Cox Award:** Helmut E. Schrank

Additionally, twelve IEEE members, whose nominations were evaluated by the MTT-S, were elected to the grade of Fellow of the IEEE as of January 1, 1991.

- Gailon E. Brehm** "For contributions to microwave circuit and semiconductor processing of GaAs monolithic microwave integrated circuits."
- Kai Chang** "For contributions to microwave and millimeter-wave circuits and power combining techniques."
- Eliot D. Cohen** "For leadership in the advancement of microwave and millimeter-wave monolithic integrated circuits."
- Paul F. Goldsmith** "For the development of quasi-optical techniques and their application to low-noise radiometers and millimeter systems."

Tsutomu Hashimoto

"For contributions to and leadership in the development of microwave transmission lines and circuits for practical satellite communication antennas."

Peter R. Herczfeld

"For contributions to the application of lightwave technology to microwave and millimeter-wave devices, circuits, and systems."

Wolfgang J. R. Hoefler

"For contributions to the modeling and design of passive microwave and millimeter-wave circuits."

Erik L. Kollberg

"For leadership in and contributions to the advancement of low-noise microwave and millimeter-wave receivers."

James W. Mink

"For contributions to quasi-optical millimeter-wave power-combining techniques for solid-state sources."

Allen F. Podell

"For contributions to hybrid and gallium arsenide monolithic microwave integrated circuits."

Robert J. Trew

"For contributions to the development of physical models and computer-aided design tools for microwave solid-state devices and circuits."

Kawthar A. Zaki

"For contributions to the analysis of dielectric waveguides and resonators and their applications in microwave filters and oscillator design."

Eleven MTT-S members whose nominations were evaluated by other Societies were also elected to Fellow grade.

ON THE OUTSIDE LOOKING IN?

Discover the advantages of belonging to the world's largest professional technical society—The Institute of Electrical and Electronics Engineers, Inc. *Join us!*

FOR A **FREE** IEEE MEMBERSHIP INFORMATION KIT USE THIS COUPON.

Name _____ ()
 Title _____ Phone _____
 Firm _____
 Address _____
 City _____ State _____
 Country _____ Postal Code _____

MAIL TO: IEEE MEMBERSHIP DEVELOPMENT

The Institute of Electrical and Electronics Engineers, Inc.
 445 Hoes Lane, P.O. Box 1331
 Piscataway, N.J. 08855-1331, USA (201) 562-5524



How We Handle Papers at the MTT

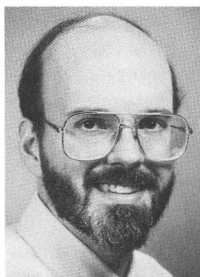

by Steve Maas, Editor
MTTS Transactions

OK, I know that a title like this leaves us open to a lot of cheap shots. The worst of it is that we probably deserve a few of them. But that's not the point; I just thought it might be worthwhile to tell you a bit about the way manuscripts are handled at the *MTT Transactions*, and that you could use that information to expedite the publication of your papers. A lot of delays are caused by misunderstandings of the ordinary ways we do things; perhaps we can avoid a few of these.

Before we get into details: a blurb entitled "Information for Authors" appears on the back cover of the MTT several times per year. This contains the minimum information necessary for dealing with the IEEE publications bureaucracy and the MTT editorial offices. *Please* read this before submitting a paper; if you don't, your paper will almost certainly be delayed. It should be easily understandable by anyone with the brains to write a technical paper in the first place.

Manuscripts

First: you *must* submit at least four copies of the original manuscript. This allows us to send it to three reviewers, and to keep a file copy (which we can copy and send to another reviewer or two if necessary). If you send fewer than four copies, we will notify you and file your manuscript until we get the required number of copies. This rarely results in less than a month's delay. (I confess that we sometimes take pity on authors from third-world countries and allow them to submit a single copy. However, if you're not from Burundi, don't expect special treatment.)

If possible, submit an IEEE copyright form with your paper. The form is printed annually in most IEEE journals; a photocopy of this form is OK (although the signatures must be original). We *must* have this form on file before the paper can be scheduled for publication. There is no harm in sending this with the original paper; if the paper is not accepted, the copyright transfer is automatically void.

We have a length limitation: all submitted papers must be less than 10 printed pages. We estimate four double-spaced typed pages or four figures as a single printed page. By the way, we're wise to all the tricks: multi-part figures count as multiple, not single, figures, and we know how proportional spacing, Postscript fonts, and continuously-variable line spacing are used to squeeze an overlong paper into something that appears to meet the limit. Also, the reviewers are not easily fooled: they are, on the whole, unusually sensitive to overlong papers. I try to discourage the submission of companion papers (companion papers are two papers on related subjects); these are often a transparent attempt to circumvent the length limitation. Furthermore, they rarely get through the review process intact: we receive about one set of such papers per month; we publish perhaps one set per year.

When your paper is received, it is logged into the computer and given a number; the computer prints a form letter acknowledging receipt. *Please* use that number in any letters or phone calls regarding the paper; we organize *everything* by paper number at the MTT. Your paper then embarks on the adventure of the review process, probably the toughest trip it will take in its entire life. Figure 1 summarizes the journey.

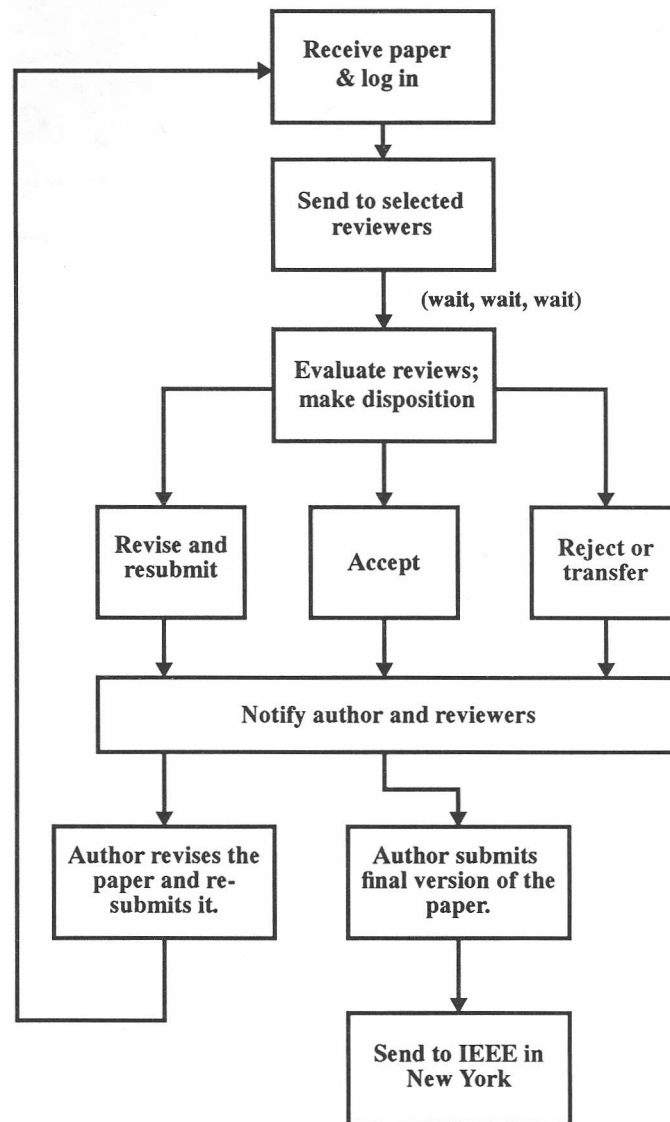

Figure 1.
The Publication Process.

The Review Process

New papers go out for review within a day or two of receipt; resubmitted papers have second priority and may have to wait a week or so. Most papers are sent to three reviewers; a few are sent to only two. We ask the reviewers to respond within six weeks, but often they need more time. Revised and resubmitted papers are sent to their original reviewers.

The greatest variable affecting the time required to process a paper is the length of the review cycle. If all reviewers responded within six weeks, all papers would be accepted or rejected within two months of submission. Some are processed this soon, or even sooner. Others may take as long as

four months. Sometimes a reviewer is on vacation, sabbatical, or sick; occasionally a reviewer (off with his head!) will hold a paper for several weeks and then decide, for one reason or another, he cannot review it; and sometimes (shame, shame!) a reviewer simply doesn't respond, even after reminders. Highly technical papers often are difficult to review, and simply require a lot of time. Others involve subjects where we have few appropriate reviewers, so many decline to review the paper before we find one or two who feel competent to do the review. Finally, sometimes we are just plain unlucky, and several reviewers (sometimes as many as five or six) decline for a number of different reasons.

The greatest problem is a reviewer who doesn't respond; he or she leaves me in a no-win situation. If I wait for a response, I risk losing time and may yet have to assign another reviewer (and wait six weeks for the review—then what if that reviewer doesn't respond?). If I do assign a new reviewer, I may receive the review from the original reviewer shortly afterward; I then feel honor-bound to await the new reviewer's response. I have also lost the services of the new reviewer, who otherwise could have been assigned to a newly submitted paper.

After reading the paper, each reviewer fills out two forms. One form includes the reviewer's candid assessment of his own competence to review the paper, comments on the paper for the editor only, and a suggestion to accept or reject the paper or to return it for revision. Authors should also remember that the decision to accept or to reject their paper is based part on the information on this form, to which they do not have access, and is often far less diplomatic than the form they receive. The second form is for the author. It is a questionnaire, and includes a general assessment of the paper, along with the reviewer's (optional) written remarks and suggestions.

What Determines Acceptance?

Now a glimpse into the editor's twisted mind. Why are certain papers accepted and others rejected? To begin with the obvious: some papers are clearly first rate and must be accepted; others unquestionably must be rejected. The other 90% are somewhere in between. It is very difficult to describe in general the decision process for these; each paper is an individual matter, and is accepted or rejected for specific reasons. I try to bring some measure of wisdom to the decision process. I can identify a few things, however, that give a paper a high probability of rejection:

- There are indications that the paper may be erroneous.
- The paper lacks originality, or contains standard, well known technical material.
- The paper is not sufficiently distinct from a similar paper, by the same author, in the MTT, MTT-S digest, or another journal.
- The techniques it describes have been superseded by newer or better methods.
- The paper lacks technical depth.
- The techniques are grossly impractical. (This is a sticky issue, because things that are impractical today may be pioneering work tomorrow: e.g., Lord Rayleigh's original work on waveguides. However, there *are* limits.)
- The single greatest cause for rejection of revised papers is an inadequate response to the reviewers' original criticisms.

Because this process is unavoidably subjective, papers that should have been accepted will be rejected on occasion (we apologize to the authors), and poor papers will sometimes be accepted (we apologize to the readers). If you feel strongly that a published paper should not have been accepted, please

let me know; I would like to review the decision process for that paper.

A paper may be accepted as a short or full-length paper. There is a great deal of confusion about the definition of a short paper. First, a short paper is *not* a substandard full-length paper; it is simply and exactly what its name implies: a paper of limited scope, addressing a subject that can be covered in three pages of the *Transactions*. Short papers do not include author biographies and can begin in the middle of a page; thus, they allow us to publish a relatively large number of papers in minimal space.

Occasionally a paper that is fairly long will be accepted as a short paper, and the author complains that he or she cannot possibly reduce it to short-paper length. This disposition is not a whim; it is based on the opinion of the reviewers that the paper's significant material could be condensed to short-paper length. If this happens to you, I apologize. Now please start cutting.

A Message to Reviewers

Thanks for your help. Without it, the *MTT Transactions* couldn't possibly work.

Now, get on the stick and review that last paper I sent you! It's in the pile on your desk, under the other work you didn't have time to do right away. I hate to nag you and to send that sanctimonious reminder letter I often use when reviewers are late. If you cannot review the paper, whatever the reason, please return it to me promptly so I can send it to someone else.

Sorry if I send you a lot of work. If so, it's probably your own fault: you have turned yourself into a well known and trusted expert, and you probably have done a good, thoughtful job of reviewing papers in the past. However, if the load is really too heavy, let me know and I will lay off for a while.

You may not be aware that we keep a computer database of our 600 reviewers, including information on their areas of specialization. If you continually receive papers that are not appropriate for you to review, give me a call; our information may be inaccurate or out of date. Also, let us know of any change of address. Conversely, if you rarely receive papers to review, it might be that we don't know enough about you. Give me a call.

Final Papers

When your paper is accepted, you will receive the following:

- an acceptance letter (yay!)
- a page-charge form
- a copyright form (unless you have sent one earlier)
- some information on figures, etc.

The page-charge and copyright forms are extremely important. They *must* be completed before your paper can be scheduled for publication; failure to return these forms is by far the most common cause of publication delays. Payment of page charges is voluntary for the first five pages of the paper (although the author's institution is expected to pay them, if possible); beyond five pages they are mandatory. The mandatory portion can be waived, but only in very special cases (e.g., authors without institutional affiliations, or from third-world countries). Be sure that your purchasing agent sends the purchase order for page charges to the IEEE in New York, *not* to me.

Authors of accepted papers are expected to make final revisions consistent with reviewers' (and occasionally the editor's) comments; if these have been ignored, the paper may be returned for revision. The author should include a brief list

of the changes; this will allow me to check them more easily, and will thus expedite publication. I also check writing quality at this point; poorly written papers may also be returned.

Only one copy of the paper and final figures is necessary. The usual publication delay is three to four months after receipt of the final paper.

After I send the paper to the IEEE in New York, it is completely out of my hands. If problems develop at this point, contact Chris Ralston at (212) 705-7356.

In a few weeks you will receive galley proofs. It is absolutely essential that you proofread these and return them by the specified deadline. If you do not, your paper will slip to the next month (or perhaps even later), and Chris and I will have to restructure the tables of contents for two issues. We hate to do this.

Figures

The sorest of sore points involves the quality of graphs, illustrations, and tables. These are reproduced as submitted; they are *not* redrawn. The quality of figures is steadily decreasing. Back in the old days, figures were hand-drawn in ink by a draftsman and were usually pretty good. Now, with the help of computers, it is easy to create figures that are almost impossible to publish successfully.

The worst of these are figures produced by dot-matrix printers. These simply are not of publication quality, especially made with the worn-out printer ribbon favored by most authors. Plotter outputs are almost as bad. The lines made by fiber-tip plotter pens are ragged and indistinct, the plots often have an inane title like "Graphics Plot," the axes are not clearly labeled, and the legends are often so cryptic they might have been written by the Oracle at Delphi. If you must use these, get an ink pin for your plotter and use good-quality paper. Finally, cut off the silly titles and legends, and use a lettering machine to redo them.

Figures produced by a computer-graphics package and printed on a laser printer are potentially very good, but authors often—dare I say *usually*—use lettering that is too small and lines that are too light. Remember, the figure will be reduced to a width of 3 inches or less; if the original is full page width, approximately 3:1 reduction is necessary. This means that the lines and lettering on a properly made original will look too large and dark. Figure 2 shows a figure that looks decidedly strange in its original form, at half-page size,

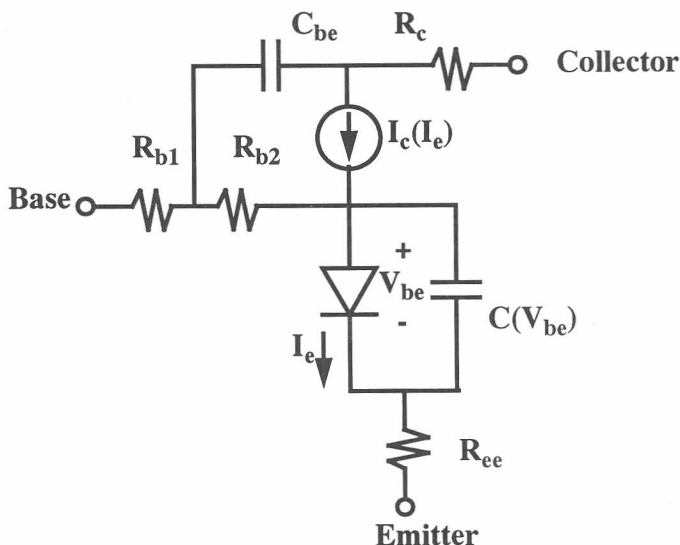

Figure 2.
A Good Figure.

but will look good in publication. Compare it to Figure 3, which is similar to most computer-generated figures we receive.

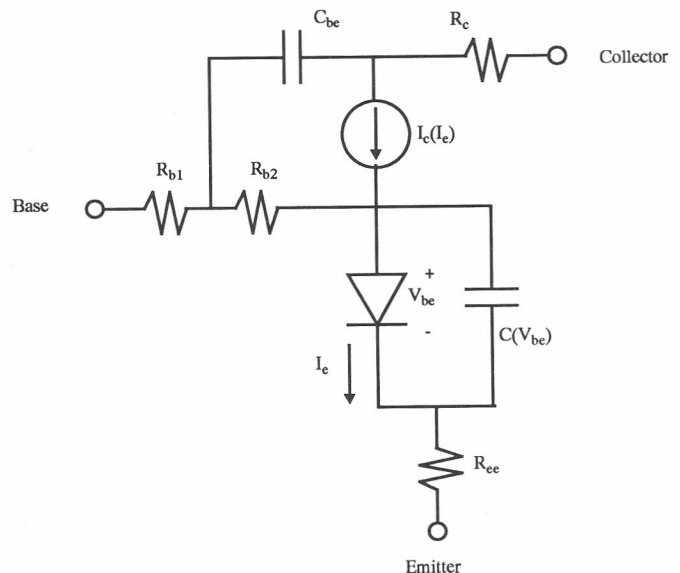

Figure 3.
A Seemingly Good Figure That Will Not Look Good When Printed.

Please send originals, not photocopies! These will be returned on request. Don't send final figures with your initial submission; you may want to change them after review. Rough-draft figures are acceptable for the initial submission, as long as they are clear.

Some Final Words

I think it's important that all of us—authors, reviewers, and the editor—keep firmly in mind the fact that the *MTT Transactions* is the premier journal of microwave technology. A publication in the *MTT* is a prestigious thing indeed, and is worth the effort necessary to assure the journal's integrity: careful preparation, prompt and thoughtful reviews, and sensible editorial action. It would be easy for this journal to sink to the level of mediocrity that characterizes many things today. Let's not let that happen. And at the same time, let's enjoy the sheer delight of dealing in, and reading about, first-rate microwave technology.

TAB Highlights

(continued from page 12)

through a combination of tighter expense control and a more businesslike relationship between the Societies and the IEEE Headquarters. The outlines thereof have been presented at this TAB meeting, but without the details required to assess the financial impact on the Societies.

My preliminary conclusion is that MTT-S' adopted 1991 budget is no longer realistic because our expenses are subject to unforeseeable increases over which the Society has very limited control. We shall address this problem at the forthcoming meeting of the MTT-S Budget Committee. We should be supportive of the efforts to reduce and ultimately eliminate the deficit of the IEEE General Fund, but without deteriorating the MTT-S finances. This will inevitably require tighter control of our expenses.

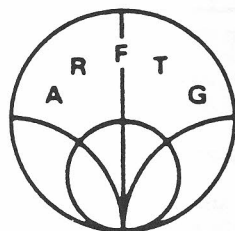

AUTOMATIC RF TECHNIQUES GROUP CALL FOR PAPERS

Boston, Massachusetts
June 13th and 14th, 1991

The Automatic RF Techniques Group will hold their 37th Conference in conjunction with the 1991 MTT-S Symposium in Boston, Massachusetts on June 13 and 14. The Conference theme is:

VALIDATION OF DESIGN BY MEASUREMENT

The objective of experimental validation is to provide unbiased, quantitative data on the quality of a design or the accuracy of design software with respect to a specific criteria. Appropriate papers include validation measurement methods, experimental techniques and approaches, performance criteria, and residual error metrics. In other words, how do we measure "good" in our designs and in our models? Of particular interest are papers which critically examine and improve upon validation techniques as applied to existing designs and design software. Papers on other automated RF measurement or computer-aided design topics are also welcome.

Technical presentations shall be informal twenty-five minute talks using viewgraphs or 35-mm slide illustrations. Authors are requested to submit a one-page abstract and a 500 to 1000 word summary with attachments containing illustrations, etc., providing sufficient technical content to enable proper evaluation and explaining the contribution's usefulness to the conference attendees. Please refer to "ARFTG Instructions to Authors" for further information. All accepted papers will be published in the post-conference digest. Two copies of the abstract and summary should be sent to Jim Rautio, Technical Program Chairman, and should be received no later than March 30, 1991. Manufacturers interested in exhibiting at the conference should contact the Exhibit Coordinator for information and an application and agreement form.

Submit Papers to:

Jim Rautio
Sonnet Software
Suite 100
101 Old Cove Road
Liverpool, NY 13090
(315) 453-3096

For exhibit Application contact:

William E. Pastori
Maury Microwave
8610 Helms Avenue
Cucamonga, CA 91730
(714) 987-4715 x239

For further information, contact the 37th Conference Chairman:

Robert M. Judish
National Institute of Standards and Technology
Division 723.01
325 Broadway
Boulder, Colorado 80301

1991 IEEE/MTT-S International Microwave Symposium — Schedule of Events

SUNDAY, JUNE 9	<i>Registration</i> 5:00 p.m. – 9:00 p.m. Hynes Convention Center (Level 2) <i>MMWMC Reception</i> 7:00 p.m. – 10:00 p.m. Marriott Copley Place (Grand Ballroom)			
MONDAY, JUNE 10	Workshops Hynes Convention Center (Level 3)			
8:00 a.m. – 5:00 p.m.	WSD UHF and Active Filter Technology Room 313			
	WSG Noise Concepts in Microwave Systems Room 305			
	WSH Amplifier Noise Measurements Room 310			
8:00 a.m. – 12:30 p.m.	WSA Microwave Photonic Systems Room 311			
8:00 a.m. – 12:00 p.m.	WSC Microwave Superconductivity Short Course Room 309			
8:00 a.m. – 12:00 p.m.	WSE/F Packaging (joint session) Room 312			
1:00 p.m. – 5:00 p.m.	WSE New Packaging Techniques for MMICs and Discrete Devices Room 309			
1:00 p.m. – 5:00 p.m.	WSF Loss, Crosstalk and Package Effects in Microwave and Millimeter-wave ICs Room 312			
1:30 p.m. – 5:00 p.m.	WSB Optical Probing of Microwave Circuits and Materials Room 311			
6:00 p.m. – 8:00 p.m.	<i>Microwave Journal</i> Cocktail Reception Museum of Science			
8:00 a.m. – 5:00 p.m.	<i>MMWMC Symposium</i> Hynes Convention Center			
8:00 p.m. – 10:00 p.m.	<i>MMWMC Panel Sessions</i> Hynes Convention Center (Rooms 309 and 310)			
TUESDAY, JUNE 11	<i>Registration</i> 8:00 a.m. – 5:00 p.m. Microwave Exhibition 9:00 a.m. – 5:00 p.m. Hynes Convention Center (Level 2)			
8:30 a.m. – 10:00 a.m.	Plenary Session Dr. Norman Ramsey, Keynote Speaker Hynes Convention Center Ballroom (Level 3)			
	Hynes Convention Center			
	BALLROOM A BALLROOM B BALLROOM C ROOM 302			
10:30 a.m. – 12:00 p.m.	A Receiver Circuits I (Joint with MMWMC)	B Non Linear Modeling & Analysis	C MIT Radiation Laboratory	D Student Papers Competition I
12:00 p.m. – 1:30 p.m.	Panel Sessions Hynes Convention Center			
	PSA Packaging: Is There a Need for Domestic Suppliers? Room 309			
	PSB GaAs MMICs for Consumer Applications Room 310			
1:30 p.m. – 3:00 p.m.	E Receiver Circuits II (Joint with MMWMC)	F Microwave Integrated Circuits	G Multi-GHz Lightwave Transmission Systems	H Student Papers Competition II 1:30 p.m. – 2:30 p.m.
2:30 p.m. – 5:00 p.m.	Open Forum I Hynes Convention Center (Rooms 304-306)			
3:30 p.m. – 5:00 p.m.	I Power Amplifiers (Joint with MMWMC)	J Advanced Techniques of Numerical Electromagnetics	K High Power Optical Switching for Ultra Wide-Band Applications	L Microwave Radiometers 2:30 p.m. – 5:00 p.m.
WEDNESDAY, JUNE 12	<i>Registration</i> 8:00 a.m. – 5:00 p.m. Microwave Exhibition 9:00 a.m. – 5:00 p.m. Hynes Convention Center (Level 2)			
8:30 a.m. – 10:00 a.m.	M Monolithic Microwave ICs I	N High Q Filters	O CPW and Other Discontinuities	P Microwave/Optical Devices and Circuits
10:30 a.m. – 12:00 p.m.	Q Monolithic Microwave ICs II	R Filters and Multiplexers	S New Guided-Wave Leakage Effects	T Microwave/Optical Circuits and Applications
12:00 p.m. – 1:30 p.m.	Panel Sessions Hynes Convention Center			
	PSC GaAs MMIC Insertion: How Important is Foundry Transportability of Designs? Room 309			
	PSD Concurrent Design Engineering for Electronic Design Automation Room 310			
2:30 p.m. – 5:00 p.m.	Open Forum II Hynes Convention Center (Rooms 304-306)			
1:30 p.m. – 3:00 p.m.	U Field Effect Transistors	V Passive Components I	W Novel Concepts and Characteristics of Planar Transmission Lines	X Biological Effects and Medical Applications
3:30 p.m. – 5:00 p.m.	Y FET and HEMT Circuits	Z Passive Components II	AA Receiver Components	BB Time-Resolved Spectroscopy and Imaging of Tissue
5:30 p.m. – 7:15 p.m.	Industry Reception Westin Hotel (Third Floor Essex Complex)			
7:30 p.m. – 10:00 p.m.	Awards Banquet Westin Hotel (America Ballroom)			
THURSDAY, JUNE 13	<i>Registration</i> 8:00 a.m. – 5:00 p.m. Microwave Exhibition 9:00 a.m. – 3:00 p.m. Hynes Convention Center (Level 2)			
8:30 a.m. – 10:00 a.m.	CC Millimeter-wave ICs and Technology I	DD Ferrites and Acoustics	EE CAD Modeling for Transmission Structures	FF Applications of Measurement Technology
10:30 a.m. – 12:00 p.m.	GG Millimeter-wave ICs and Technology II	HH Microwave and Millimeter-wave Packaging	II 3-D Field Theory-Based CAD	JJ On-Wafer and Noise Measurements
12:00 p.m. – 1:30 p.m.	Panel Sessions Hynes Convention Center			
	PSE Is 100% RF On-Wafer Testing Necessary for MMIC Production? Room 309			
	PSF Microwave Hardware Description Language: What Is It? Why Do We Need It? Room 310			
1:30 p.m. – 5:00 p.m.	ARFTG Conference Westin Hotel (Third Floor Essex Complex)			
1:30 p.m. – 3:00 p.m.	KK Microwave System Applications	LL Solid State Devices and Circuits (Non-FET) I	MM CAD for Yield and Noise Characterization	NN Superconducting Microwave Components
3:30 p.m. – 5:00 p.m.	OO Phased and Active Array Techniques	PP Solid State Devices and Circuits (Non-FET) II	QQ High Power Devices and Systems	RR Superconducting Filters
FRIDAY, JUNE 14	<i>Registration</i> 8:00 a.m. – 5:00 p.m. Hynes Convention Center (Level 2)			
8:30 a.m. – 3:45 p.m.	ARFTG Conference Westin Hotel (Third Floor Essex Complex)			
8:00 a.m. – 5:00 p.m.	Workshops Hynes Convention Center (Level 3)			
	WSI MMIC & MIC Solid State Power Amplifier Efficiency			Room 310
	WSJ GaAs MMIC System Insertion and Multifunction Chip Design Issues and Trends			Room 312
	WSK High Power Microwave Systems			Room 313
	WSL Computer Applications in Electromagnetics Education			Room 305
	WSM Design, Fabrication and Packaging of High Temperature Superconducting Microwave Devices			Room 309
	WSN Spread Spectrum Technology in Consumer Electronics			Room 311

CONFERENCE HOUSING



1991 IEEE MTT-S INTERNATIONAL
MICROWAVE SYMPOSIUM



June 10-14, 1991 • Boston, Massachusetts

MTT-S • MMWMC • ARFTG

SEND COMPLETED FORMS TO:

IEEE MTT-S Housing Bureau
Prudential Plaza
P.O. Box 490
Boston, MA 02199

COMPLETED FORMS
MUST BE RECEIVED AT
THE HOUSING BUREAU
BEFORE MAY 10, 1991

SEND NO CHECKS OR MONEY TO THE HOUSING BUREAU

Hotel locations and rates are shown on the reverse side of this form.

INSTRUCTIONS AND HOUSING BUREAU POLICY

1. Please print or type all data requested.
2. All room reservations must be made by mail. **No telephone calls will be accepted.**
3. All reservations will be processed on a first-come, first-served basis.
4. Hotels will confirm reservations directly.
5. After 5/10/91 notify the hotel which confirms the reservation of all cancellations and changes. Prior to this, contact MTT-S housing at the above address.
6. Copies of this form may be used to reserve more than three rooms for which it provides.
7. **Send no checks or money to the housing bureau!**

HOTEL PREFERENCE

(Please write full name of hotel and show at least three choices.)

First choice _____ Third choice _____
Second choice _____ Fourth choice _____

Confirmations for all rooms reserved will be sent to:

NAME _____ Last _____ First _____
COMPANY _____
ADDRESS _____
CITY _____ STATE _____ ZIP _____
COUNTRY _____ PHONE (_____) _____

To guarantee, provide the following credit card information:

CARD NAME: AM. EXP. M*CARD VISA OTHER _____
CARD HOLDER NAME _____
CARD NO. _____ EXP. DATE _____

ROOM OCCUPANTS

1. Print or type names of people occupying each room.
2. Select room type desired, indicate arrival and departure dates and arrival time.

Occupants (last name first)

ROOM NO. 1	1.	Check one: <input type="checkbox"/> Single <input type="checkbox"/> Double <input type="checkbox"/> Twin <input type="checkbox"/> King Arr. Date _____ Dep. Date _____
	2.	<input type="checkbox"/> Smoking <input type="checkbox"/> Non-smoking <input type="checkbox"/> Handicap
ROOM NO. 2	1.	Check one: <input type="checkbox"/> Single <input type="checkbox"/> Double <input type="checkbox"/> Twin <input type="checkbox"/> King Arr. Date _____ Dep. Date _____
	2.	<input type="checkbox"/> Smoking <input type="checkbox"/> Non-smoking <input type="checkbox"/> Handicap
ROOM NO. 3	1.	Check one: <input type="checkbox"/> Single <input type="checkbox"/> Double <input type="checkbox"/> Twin <input type="checkbox"/> King Arr. Date _____ Dep. Date _____
	2.	<input type="checkbox"/> Smoking <input type="checkbox"/> Non-smoking <input type="checkbox"/> Handicap

1991 IEEE MTT-S International Microwave Symposium

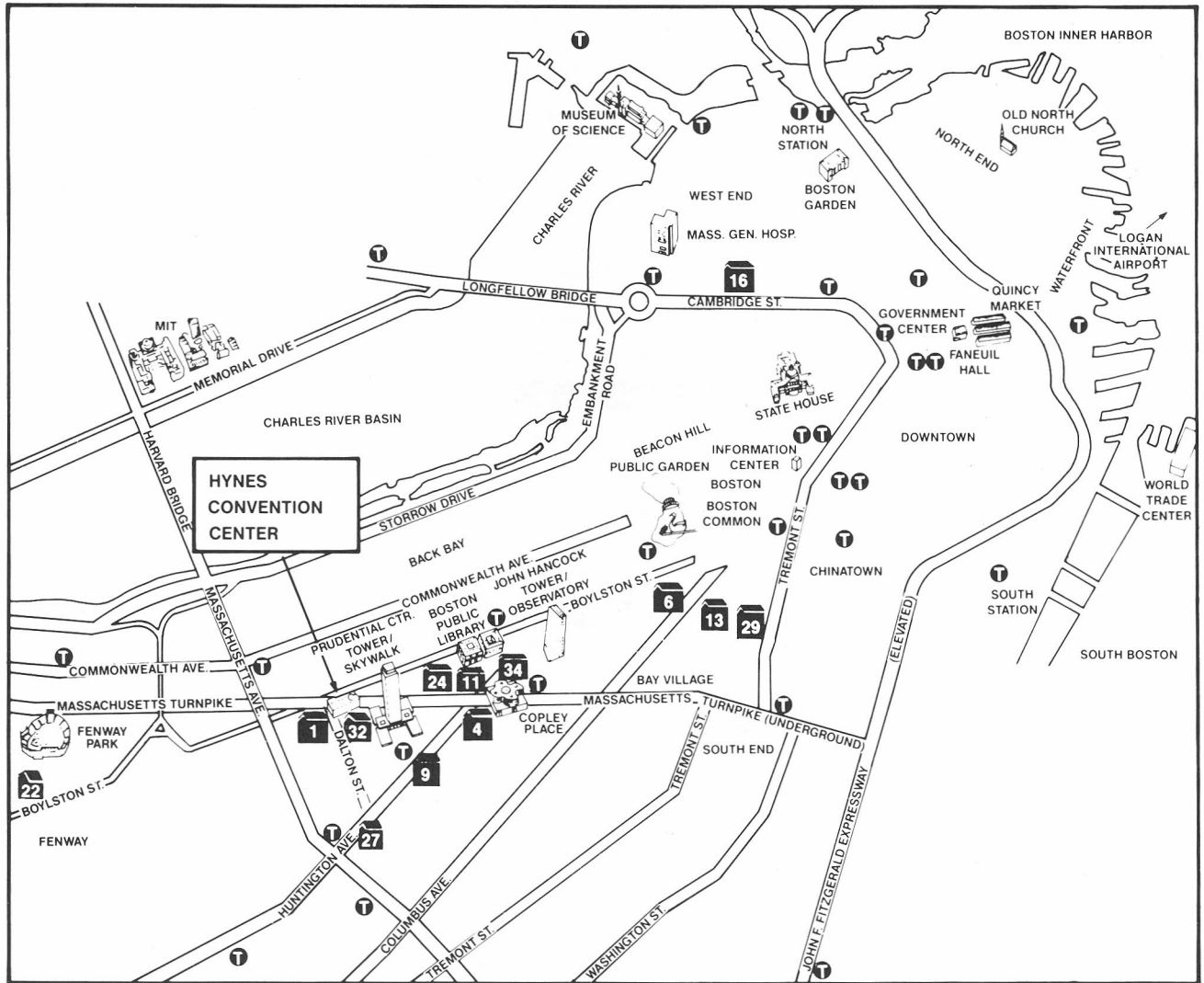

LOCATION ON THE MAP	CONFERENCE HOTELS	SINGLE	DOUBLE	GOV'T RATE
4	MARRIOTT, COPLEY PLACE	\$140	\$158	\$79/\$79
34	WESTIN, COPLEY PLACE	\$128	\$148	\$80/\$100
32	SHERATON BOSTON	\$132/\$160	\$148/\$176	N/A
1	BACK BAY HILTON	\$127	\$147	\$79/\$79
22	BEST WESTERN	\$95	\$105	\$79/\$89
9	COLONNADE	\$132	\$140	N/A
11	COPLEY SQUARE	\$92/\$100	\$105/\$115	N/A
*	HILTON AT DEDHAM PLACE	\$85	\$85	\$75/\$90
16	HOLIDAY INN, GOV'T CENTER	\$110	\$126	N/A
24	LENOX	\$125	\$145	N/A
27	MIDTOWN	\$85	\$95	N/A
6	PARK PLAZA	\$120	\$120	N/A
13	57 PARK PLAZA	\$100	\$110	\$80/\$90
29	TREMONT HOUSE (QUALITY INN)	\$95	\$110	N/A

*Located on the commuter rail line 20 to 25 minutes from downtown Boston

MTT CO-HEADQUARTERS HOTELS — MARRIOTT, WESTIN
 ARFTG HEADQUARTERS HOTEL — WESTIN

To ensure advanced registration, form and payment must be received before May 24, 1991. (If requesting Boston Pops tickets, conference registration is required by April 30th.)

Registration Checklist

- ___ 1. Make copies of this form if needed for other registrants; use a separate form for each registrant.
- ___ 2. Clearly print or type the following information in the top portion of the form:
 - your name (last, first)
 - your affiliation (i.e. company, school)
 - your address (include zip code, and country for foreign registrants)
 - your telephone number (including area code)
 - your job title (reference the number codes)
- ___ 3. Check the appropriate yes or no box to indicate IEEE membership and include your membership number. You must provide this information to receive the IEEE membership discount.
- ___ 4. Check the appropriate boxes to indicate all events for which you are registering.
- ___ 5. Enter the applicable fee for each selection on the remittance line.
- ___ 6. Total all fees and enter the total in the Total Remittance box.
- ___ 7. Make out a check or money order for the total remittance amount to:

1991 IEEE MTT-S Symposium

 - Payments must be in U.S. dollars only (check or money order).
 - Personal checks must be encoded at the bottom with the bank number, account number, and check number.
 - Bank drafts are unacceptable.
- ___ 8. Or, pay by credit card by entering the following information:
 - Card type (Master card or Visa, only)
 - Card number
 - Expiration date
 - Signature
- ___ 9. Mail registration form(s) with your payment to:

1991 IEEE MTT-S Symposium
c/o LRW Associates
1218 Balfour Drive
Arnold, MD 21012, USA

On-Site Registration Fees

MTT-S Symposium Attendance	IEEE Member	Non-Member
All MTT-S sessions	\$210	\$295
Single-day registration	\$105	\$140
Retiree, Student, Life Member	\$ 25	\$ 25
Automatic RF Techniques Conference		
ARFTG Member	\$240	\$240
ARFTG Non-Member	\$265	\$265
MMWMC Symposium	\$ 80	\$ 95
Panel Sessions	\$ 15	\$ 15
Workshops		Student, Retiree Life Member
Full Day	Attendee \$ 75	\$ 40
Half Day	\$ 45	\$ 20

STEERING COMMITTEE

Chairman

Peter Staecker
M/A-COM, Inc.
(617) 272-3000 ext. 1602

Vice-Chairman

Dick Sparks
Raytheon Company
(508) 858-1355

Technical Program

Dan Masse
Raytheon Company
(617) 860-3081

Glenn Thoren
Lockheed/Sanders Inc.
(603) 885-2988

Local Arrangements

John Putnam
M/A-COM, Inc.
(617) 272-3000 ext. 1584

Finance

Steve Temple
Raytheon Company
(508) 858-5083

Art Blaisdell
M/A-COM, Inc.
(508) 881-3482

Publicity

Howie Vogel
Hewlett Packard Co.
(617) 221-5000

Ralph Marrone
Hewlett Packard Co.
(617) 221-5168

Special Events

Joseph White
Applied Microwave Magazine
(617) 863-9603

Special Issue Editor

Zvi Galani
Raytheon Company
(617) 274-4184

Symposium Digest

George Heiter
AT&T Bell Laboratories
(508) 960-6031

Registration

Cliff Drubin
Raytheon Company
(508) 858-4214

Guest Programs

Mikelle Carr
The Abacus Group
(508) 456-8558

Susan Staecker
MIT Lincoln Laboratory
(617) 981-4164

RadLab Celebration

Ted Saad
Sage Laboratories
(508) 653-0844

Historical Exhibit

Roger Sudbury
MIT Lincoln Laboratory
(617) 981-2999

MMWMC Liaison

Rick Gold
Massachusetts
Microelectronics Center
(508) 870-0312

ARFTG Liaison

Harry Cronson
MITRE Corp.
(617) 271-6917

Chapter Liaison

Tom Perkins
Lockheed/Sanders Inc.
(603) 645-5516

Exhibition

Howard Ellowitz
Horizon House
(617) 769-9750

1991 IEEE MTT-S INTERNATIONAL MICROWAVE SYMPOSIUM

June 11-14, 1991 • Boston, Massachusetts



PREPUBLICATION OFFER TO MTT MEMBERS

1991 SYMPOSIUM DIGEST OF PAPERS (Three-volume set)

In response to membership requests and as a special service, the 1991 Symposium Digest of Papers is offered again at a prepublication discount rate. ONE copy of the Digest is offered to members in good standing at the price of U.S. \$35.00, which includes shipping via surface mail.

To order, complete the attached form and include payment or credit card information. All orders must be received by April 2, 1991 and will be shipped from the IEEE Service Center approximately at the time of the symposium.

IEEE SERVICE CENTER
MTT-S DIGEST OFFER
445 Hoes Lane
P.O. Box 1331
Piscataway, NJ 08855-1331, USA

DEADLINE: ORDER MUST BE RECEIVED
BY April 2, 1991

Please send me ONE 1991 IEEE MTT-S International Microwave Symposium Digest.

- I have enclosed payment of U.S. \$ _____ for the Digest (3-volume set).
- Please charge my credit card: _____ VISA _____ MasterCharge _____ American Express

Credit Card No. _____ Expires _____ Signature _____

Price in U.S. Funds \$35.00

Includes mailing cost:
- UPS in U.S. and Canada
- Surface mail elsewhere

NAME: _____

MEMBER NO: _____

Added Cost for Air Mail:
- Mexico & So. America (U.S. \$15.00)
- Europe & Mediterranean (U.S. \$30.00)
- Asia & All Other (U.S. \$45.00)

ADDRESS: _____

\$ _____

TOTAL \$ _____



1992 IEEE
MTT-S

International Microwave Symposium

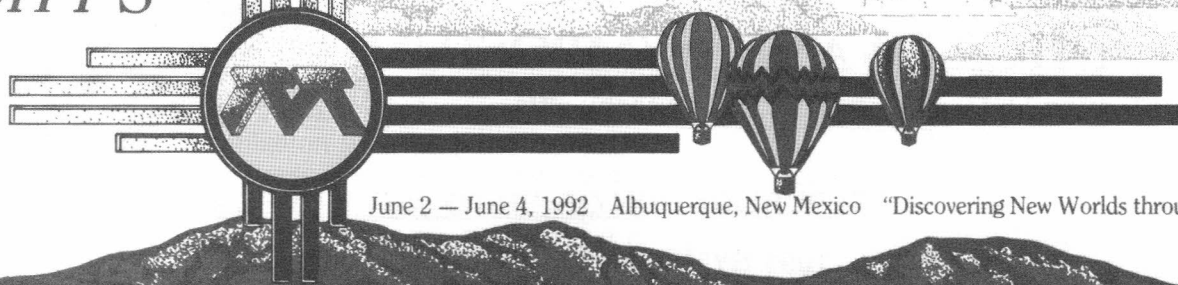

June 2 — June 4, 1992 Albuquerque, New Mexico "Discovering New Worlds through Microwaves"

"ABQ in 92"

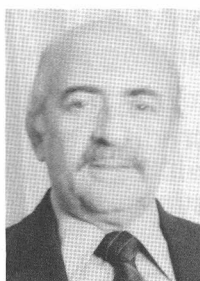

by Jerry Hausner, Chairman
1992 IEEE MTT-S IMS Steering
Committee

As the 1992 MTT-S Symposium rapidly approaches, excitement and anxieties begin to build in the Steering Committee. As shown some members of the committee are engaging in the Great Symposium Prayer Dance. Kidding aside, this symposium presents a unique opportunity to the attendees. Not only will they be exposed to the latest developments of the microwave industry but also to other American cultures. Most of our people have not previously had the chance to visit this magnificent part of the world. The major industry of New Mexico is research, development and the

advancement of technology. This is exemplified by the Rio Grande Research Corridor, a project which establishes five technical centers of excellence. Participating in this effort are two national laboratories, Los Alamos and Sandia, the Air Force Weapons Lab (now called Phillips Lab), White Sands Missile Range, The University of New Mexico, and New Mexico State in Las Cruces.

(photo)

The theme we chose is "Discovering New Worlds Through Microwaves." It is based on several considerations:

- 1992 marks 500 years since Columbus discovered the new world.
- Goddard's first rocketry work was performed in Roswell, NM.
- Socorro, NM, is the site of the Very Large Array (VLA) radio telescope.
- 1992 has been designated as International Space Year.
- 1992 is the year the European economic community joins together to form their new world.

Discovering new worlds is not limited to outer space. Microwaves are continuously finding applications in the inner world, such as biology and medicine. This exemplifies the means by which our industry will participate in the rebirth of major industries.

The technology which produced the prosperity of the past may not be the technology of the future. Fortunately, huge amounts of research and development have been conducted which can significantly contribute to the industries of tomorrow. Most of this technology has been developed under the auspices of the government and the time is ripe to capitalize on this wealth. The current Gulf situation certainly demonstrates that we must remain strong and continue our defense efforts. However, much of the knowledge gained can be transferred to the private sector and applied to the improvement of our general quality of life. The areas for which we can find applications of microwave devices and techniques include:

- Medicine
- Entertainment
- Communications
- Construction
- Manufacturing
- Space Exploration
- Transportation
- Environmental Improvement

The new buzz word associated with this concept is **tech transfer**. Several efforts have been started under this name and I would like to see these coordinated to be more effective. To this end I am entertaining the idea of a special session on the methods and efforts of Tech Transfer. If anyone has any ideas or contributions to such a session, please pass them along to me. Your participation is appreciated and your attendance will be rewarding.

Jerry Hausner may be contacted at (505) 842-8911 or by fax at (505) 242-2249.



Indian Dances—Spectacular Ceremonial Dances take place throughout the year at all the Indian Pueblos of the Rio Grande Valley. Many dances and costumes such as these at the Indian Pueblo Cultural Center in Albuquerque are very realistic in the representation of nature and animals.

MTT-S Historical Collection

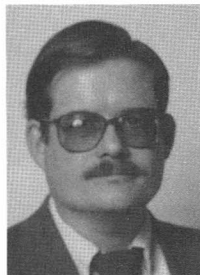

by Steven N. Stitzer
Chairman, MTT-S Historical Collection

In 1980, Ted Saad assembled the MTT-S Historical Collection for the Washington, DC, International Microwave Symposium. The steering committee asked for volunteers from the Baltimore Chapter to help "man the display." I was one of those volunteers, and I could not have guessed how involved I would become seven years later. In 1983, the Historical Electronics Museum, founded by Bob Dwight, opened to the public near Baltimore-Washington International Airport. Warren Cooper suggested to Ted that the Museum could be a permanent home for the Collection when it was not being displayed at each year's Symposium. Ted agreed and shipped five packing crates and several cartons of artifacts and books to their new home in December 1987.

A committee of local MTT members, Ted Nelson, John Gipprich, and I (all ex-Chapter Chairmen), was formed to oversee the Collection. Ted Saad came down to Baltimore and we opened everything up for inspection. We were very impressed with the care he had taken in packing the artifacts in hand-cut foam layers in the crates. Ted told us about his experiences with shipping and some other logistics issues, but the responsibility for coping with future Symposia was left to us.

Our first decision was to mount the artifacts in semi-permanent display cases to minimize the handling of individual items during setup each year. The cases were designed by Ellen Prucha of Westinghouse. After three years and shipping the exhibit to both coasts, we should know what we are doing, but each year still has its surprises. In New York, we learned that the agents at the warehouse where all exhibit materials are collected before being sent to the Convention Center expect each incoming shipment to be weighed, since the charges for getting material to the Convention Center are based on weight. We had used a local trucking firm and our driver told us he had more than a little trouble getting his truck weighed in New York that day.

When the Collection was brought to Baltimore, it comprised 126 artifacts, and about as many books, photos, and other paper items. Since then, the number of artifacts has grown to 211. (OK, a few are duplicates; does anybody have anything to swap for a 2C40 lighthouse triode?) Committee member Jeff Kruth and I have been scouring the ham radio flea markets looking for old microwave equipment, and between us we have added 45 items. It is always fascinating to try to identify some of the items found. It is equally satisfying to locate a photograph and description of an item in one of the Rad Lab volumes or other literature from that era. One example was an X-band radar duplexer pictured in the 1950 NAVSHIPS *Microwave Techniques* text. I had found it at the Dayton hamfest just a month before the Long Beach Symposium. It was even more fun to hear Ted Saad exclaim that he remembered working on it at the Rad Lab!

We have also added about a dozen books, some new and some old. With help from Rod Burman of the European Military Microwaves Conference, we hope to expand the scope of the Collection to include more of the British and European microwave contributions to the art. We are always on the lookout for items, especially if they are accompanied by an explanation of their historical significance in the development of microwaves. Please contact me if you are willing to donate or loan items that you think may be of interest to other MTT members.

The emphasis this year will be on the Radiation Laboratory, and many of the items in the Collection will be highlighted to indicate their heritage from that organization. We will also have an active display of Rad Lab era (\pm a few years) equipment, with a slotted line setup to remind us how microwaves got measured 50 years ago. If you are going to the Symposium this year, be sure to stop by and see the Historical Exhibit, which is being coordinated by Roger Sudbury. If you are in or around Baltimore, you can see the Exhibit along with the SCR-584 radar used in the Nova TV show "Echoes of War," an SCR-270 radar which is in the process of being refurbished, and many other interesting pieces at the Historical Electronics Museum, (301) 765-2345.

Winter MTT-S AdCom Meeting Highlights

(continued from page 12)

Open Forum Sessions include an invited speaker for each session. The speaker exchange program with the European Microwave Conference produced three excellent invited speakers. A highlight of the 1991 Symposium is the Rad Lab Celebration. Roughly 300 Rad Lab alumni are expected to attend and special exhibits are planned.

The Technical Coordinating Committee was a priority item at this meeting. Eliot Cohen, the 1991 Vice-Chairman, delivered the report for this committee. He highlighted the Emerging Technologies Workshop which was held just prior to the AdCom Meeting. Several recommendations came out of the workshop that were approved by AdCom.

The Editor's Reports were also priority items on the agenda. The *MTT-S Transactions* editor, Steve Maas, reported that 430 papers were submitted in 1990. Tatsuo Itoh reported on the new *Microwave and Guided Wave Letters Journal*. You should have received at least the first three issues by the time you read this report. The target of a 3-month submission-to-publication cycle was almost met for the January issue. John Wassel, the new *MTT-S Newsletter* Editor, then gave a brief report.

The final priority item was the Ad Hoc Committee on "MTT-S Week" structure. This committee started its work under the Meetings and Symposia Committee and was elevated to an Ad Hoc Committee reporting directly to AdCom. Our symposium week schedule is packed with workshops, technical sessions, the industry exhibits and committee meetings. The Ad Hoc Committee will make recommendations to AdCom on how the structure of our symposium week might be improved. I'm sure the committee chairman, Barry Spielman, would appreciate your comments.

The various brief reports given by other committees will not be summarized here. Thanks to all AdCom members, committee chairmen, committee members and guests for a successful meeting.

Viewpoints

Can the U.S. Regain Industrial Leadership Using Second-Class Labor?



by Les Besser

The high-tech revolution of recent decades has completely changed the demand placed on the industrial work force. As manufacturing and other business procedures have become more advanced, the level of science, communications and other vital skills needed in the workplace has skyrocketed. Business leaders agree that workers of tomorrow must be able to read and write; to clearly communicate with superiors, peers and subordinates; to follow verbal and written instructions; to work with complex software and hardware; to solve problems; to initiate changes and improvements; and to continue the learning experience.

This is a tremendous expectation, considering that an estimated 25 million Americans, over the age of 18, are functionally illiterate. They cannot read or write well enough to fill out job applications, or read and understand newspaper headlines. Many are also incapable of understanding our political structure or balancing their checkbooks. These disadvantaged individuals cannot be trained for meaningful jobs, because they lack the fundamentals of a basic education—despite the fact many of them possess high school diplomas.

In the area of science, the picture is even more alarming; it shows up at the elementary school level, becoming progressively worse in high school. At age 10, American students rank seventh in terms of scientific knowledge in a field of 15 industrial countries. By age 15, Americans rank next to last in the group.

Education is the source of economic growth and prosperity—it is the foundation of our ability to compete in a changing world economy. Without an educated work force, America will be left behind. We cannot be a world-class industrial power with a second-class work force. American education is failing because it is out of step with the new social and economic realities brought on by new domestic and global infrastructures.

The world has changed. But our schools are still operating as they did 100 years ago, when we were still an agrarian society. Unless they change drastically, the U.S. will be reduced to a second-class economic power in the world. As John Clendinin, Chairman of the U.S. Chamber of Commerce, states, "The bottom line is, America's fight for long-term competitiveness ultimately will be won not in the halls of Congress . . . not in the boardrooms around the world . . . but in America's classrooms."

A frightening statement, considering the status of our public education system. When the realities of our current budget problems are factored in, the picture gets even gloomier. Although the 1989 U.S. Educational Act recognized our difficulties and offers guidelines to correct them, government money alone rarely solves problems of this scope. What is needed is the involvement of individuals and business, put-

ting aside our short-term interest to guarantee long-term success.

Let's look at possible solutions that we can all participate in:

1. Recognize and reward teaching as a profession. Not long ago teachers were respected members of the community. Today, teachers confront an indifferent, often hostile public, while being placed on the low end of the economic scale. They feel isolated from both parents and community support. They often are subjected to verbal and physical abuse from the students they are trying to teach. Many capable teachers, unless they are extremely devoted, switch to industrial jobs (with significant pay increase).
2. Show students that the world needs technical minds to guide us into the next century. Help bring the excitement of science into classrooms. Sponsor science fairs, competitions to show the practical and useful applications of math and science, instead of memorizing boring formulas.
3. Convince students and parents that "hard work" should be a popular concept. Most everyone admires athletes for their physical power and agility, but students that work and study hard are considered "nerds" and disparaged by their peers. Asking American parents what is most important for academic success, the most frequent answer is "ability." Oriental parents reply, "effort."
4. Convince your company to sponsor a school by donating equipment, personal time and managerial skills. Classrooms are notoriously under-equipped and most teachers are not "computer literate." Teachers need tutoring on new skills and techniques, and how to incorporate computers into their curricula.
5. Ask your company to offer part-time or summer jobs to students and faculty. Being in a "real-life problem-solving" environment can help capture the students' interest in a scientific career, resulting in more focused and meaningful education.
6. Tutor math and science students. These subjects are often taught by teachers without necessary background or skills. We can prevent marginal students from having an "anti-science" attitude by presenting a different view. (It may also help us become more sympathetic to students' frustration when reading some of the so-called "textbooks.")

Our schools must also recognize that our society has changed since World War II and respond to the presence of drugs, teenage pregnancies, massive immigration (legal and illegal), television, permissiveness, and the erosion of the traditional family. We need year-around schools, extended school days, more day care centers, and performance based curricula. Making schools safer and more pleasant are also important. Learning will not take place where vandalism, disruption and physical danger exist to students and teachers.

These are only a few suggestions from a long list of needs. However, I want to re-emphasize *personal involvement* in local communities. Without it education is doomed for failure. Donating money is great, but being there in person is far more effective.

Engineers are often accused (just or unjust) of not being "people-oriented." Here is an excellent opportunity for changing that negative image and, at the same time, helping shape the future of our country. It is a "win-win" situation and we all need to be involved.

The Editor will consider contributions from MTT-S members expressing timely and relevant items of interest to our technical community. Submissions should be limited to 300-500 words. Opinions expressed in Viewpoints are solely those of the author(s) and do not reflect an official position of the MTT Society.

IEEE Division IV Director's Report

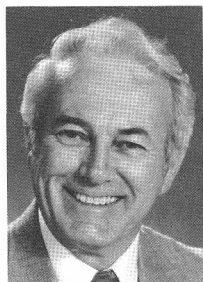

by B. Leonard Carlson
*Division IV: Electromagnetism and
Radiation*

During the past three months, aside from the normal Director's duties, I have participated in three significant IEEE functions:

1. The Region 9 Colloquium (September 1-15, 1990),
2. The Society Chapters Coordinators Workshop in Toronto (October 4, 1990), and
3. The Sections Congress 90 chapters Plenary and Workshop Sessions (October 5-7, 1990).

During the Region 9 Colloquium a team made up of Region 9 Director, IEEE President Carlton Bayless, members of TAB/TAD, and distinguished lecturers from participating societies visited Rio de Janeiro and San Paulo, Brazil; Buenos Aires, Argentina; Montevideo, Uruguay; and Santiago, Chile. In each of these cities technical presentations and industrial and educational institution visits were made by IEEE volunteers. In addition, while visiting each city, a two-part round table discussion was held during which the visiting IEEE members provided short presentations on RAB/TAB activities as they pertain to the Section and Chapters. I presented a briefing on RAB/TAB Chapter activities, E-Mail, video taping, and chapter operations guide. The second part of the round table was devoted to the local IEEE Section/Chapter volunteers presenting any problem, perceived or real, having to do with IEEE activities in Region 9.

At the end of the round table discussions, issues were formulated for action with both an in-country IEEE volunteer contact and an IEEE delegate to follow up on the mutual action item. Some of the key issues are as follows:

1. The Region 9 Sections would like to have more technical seminars with small groups (2-3 people) for 3 to 5 days in length, with plenty of prior coordination on subjects to be discussed.
2. The IEEE (EAB) needs to make more technical course seminars available to chapters in South America and, if possible, in Spanish. (English is not as prevalent as in the past, seems to be a trend according to some of the older members.)
3. Need more communications between Societies and Chapters, e.g., Chile has never hosted a technical conference. There is very little, if any, communication between the Societies and the Chapters.

There are many more issues, and these will be included by the Region 9 Colloquium Chairman in his report.

A Society Chapters Coordinators workshop was held in Toronto on 4 October 1990. A list of 12 workshop topics were provided by the attendees during the meeting. This was reduced to three topics as follows:

1. Communications
2. Chapter Development
3. Chapter Needs

During the workshop, presentations were made by three Society Chapter Coordinators on "How We Take Care of Our Chapters." The number of Chapters per Society ranged in size from 5 to 33, scattered throughout all IEEE regions. The workshop identified some real challenges for the role of the Chapters Coordinators within the Society. It was pointed out that the Power Engineering Society has a Chapter Council (approaching in size the AdCom's on some of the smaller societies) which cares for and feeds its Chapters throughout the world using 4 manuals, each describing Society and Chapter roles.

Results of the workshop will be mailed to all the Societies.

The Sections Congress '90 gave the volunteers from the Chapters, Societies, and Sections an opportunity to interact. As a result, many issues were discussed and a prioritized listing was formulated and submitted to the various IEEE entities for consideration and resolution.

This will be my last column as the IEEE Director for Electromagnetics and Radiation. As of 1 January, Dr. Martin V. Schneider of the Microwave Theory and Techniques Society will assume the duties of your representative on the IEEE Board of Directors. Dr. Schneider is with AT&T Bell Laboratories, P.O. Box 400, Holmdel, NJ 07733. Telephone (201) 888-7122.

In retrospect, the past two years have passed all too quickly, and much has happened during my tenure as your representative on the IEEE Board of Directors. Probably the most noteworthy is the restructuring of the Technical Activities Board (TAB) volunteers to more directly involve the Societies in the decision-making process. The Staff Technical Activities Department was also reorganized to handle the workload due to increased membership and expansion of technical activities. An attempt was also made to restructure the IEEE volunteer organization and was eventually postponed at the November BOD meeting. Results of an outside study to increase the efficiency of the IEEE Staff operations were implemented. The Publications Department was revamped and desktop publishing explored in order to become more competitive with outside publishers. Electronic mail is being studied and implemented in selected areas on a trial basis. A RAB/TAB Chapters Committee was established, composed of representatives from both the Technical and Regional Activities Boards. The committee was charged with improving relations between Chapters and the Societies and Sections. An IEEE Branch Office was established in Region 8 in conjunction with the Computer Society Office in Brussels, Belgium. A study to locate another office in Region 10 is underway. A Video Training Committee was started to provide Societies with training material for incoming officers.

All in all, it has been an exciting and busy two years, and I've especially enjoyed meeting and working with the members and volunteers of the five technical Societies that make up Division IV (Electromagnetic Compatibility, Antennas and Propagation, Microwave Theory and Techniques, Nuclear and Plasma Sciences and Magnetics). Keep up the good work. I plan to remain active in the Technical Activities Board and with the RAB/TAB Chapters Committee.

ARFTG Highlights

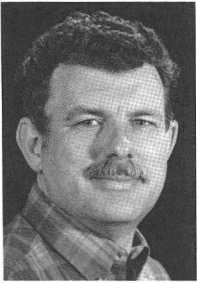

by John T. Barr IV

The Automatic RF Techniques Group (ARFTG) is an independent professional society that is affiliated with MTT-S as a conference committee. ARFTG's primary interests are in computer-aided microwave analysis, measurement and design. ARFTG holds two conferences each year, one in conjunction with the MTT-S International Microwave Symposium and a second in the later fall.

37th ARFTG Conference Announcement

The 37th ARFTG Conference will be held in conjunction with the 1991 IEEE MTT-S Symposium in Boston, MA. This one and one-half day conference starts at 1:30 p.m. on Thursday, June 13, and concludes at 5:00 p.m. on Friday, June 14. This allows easy attendance for those attending the MTT-S or MMIC Symposiums earlier in the week. Technical sessions, manufacturers's exhibits and Awards Banquet will be held in the Sheraton-Boston Hotel. The Sheraton Hotel is conveniently located next to the Boston Convention Center where the MTT-S technical sessions and exhibits will be held.

The theme of the 37th ARFTG Conference will be *Validation of Design by Measurement*. The objective of experimental validation is to provide unbiased, quantitative data on the quality of design or the accuracy of design software with respect to a specific criterion. Desired are appropriate papers on validation measurement methods, experimental techniques and approaches, performance criteria and residual error metrics. In other words, how do we measure "good" in our designs and in our models. Those interested in participating should contact Conference Chair: Robert Judish, NIST, Division 723.01, 325 Broadway, Boulder, CO 80301, (303) 497-3380, or Conference TPC: Jim Rautio, Sonnet Software, Suite 100, 101 Old Cove Road, Liverpool, NY 13090, (315) 453-3096.

In addition to the technical presentations, the attendees will have ample time for informal discussion among themselves during the breaks and during the provided lunch and dinner (your spouse is invited to the Banquet at no extra cost). There will be time for discussion with vendors and viewing of exhibits to see the latest in automation and measurement products. The registration fee includes technical sessions, exhibits, and all meals and break refreshments, one year membership in ARFTG and a post-conference digest of the presented papers.

36th ARFTG Conference Wrapup

The 36th Conference was held in Monterey, CA, and the topic was "On-Wafer Testing II." In attendance were 91 technical attendees plus 17 tables in the concurrent exhibitors' room. Topics included S-parameter, noise, power and package measurements of linear and non-linear DUTS. Traceability, results of a noise measurement round robin, computer-aided modeling of probing structures and standards and au-

tomatic test executives were also discussed. The papers and presenters were:

- *Comments Concerning On-Wafer Noise Parameter Measurements*, D. Wait, NIST
- *Improvements to On-Wafer Noise Parameter Measurements*, B. Hughes, Hewlett-Packard
- *Results of an On-Wafer Noise-Parameter Measurement Comparison*, J. Raggio, TRW
- *Verification of Calculations Made by the ATN NP5 Noise Figure Measurement System*, M. Lucas, Kansas State University
- *A Multi-Line Calibration for MMIC Measurement*, R. Marks, NIST
- *LRM and LRRM Calibrations With Automatic Determination of Load Inductance*, A. Davidson, Cascade Microtech
- *MMIC Package Characterization With Active Loads*, K. Phillips, NIST
- *Progress Toward MMIC On-Wafer Standards*, D. Williams, NIST
- *The Interpretation and Use of S-Parameters in Lossy Lines*,* D. Williams, R. Marks, NIST
- *On-Wafer 3-Port Characterization of Microstrip Transistors for MMIC Circuits*, G. Martin, Boeing
- *Large Signal 2nd Harmonic On-Wafer MESFET Characterization*, A. Ferrero, Politecnico di Torino
- *An Automated System for On-Wafer DC, S-Parameter, Power and Harmonic Measurements of Broadband GaAs*, K. Kerwin, Hewlett-Packard
- *Software for Automated On-Wafer Tests*, G. Lewis, ITT
- *On-Wafer S-Parameter and Waveform Measurements*, H. Cronson, Mitre
- *An Investigation of the Characteristics of Coplanar Waveguide and Terminations for Application in On-Wafer Calibration Standards*, B. Brim, Hewlett-Packard
- *On-Wafer Characterization of CPW Discontinuities by a 1-Port Method*, H. B. Sequeira, Martin Marietta
- *A V-Band Wafer Probe*, E. Godshalk, Cascade Microtech

A conference digest is available, contact: Henry Burger, ARFTG, 1008 East Baseline Road, No. 955, Tempe, AZ 85283-1314. Cost is \$20.00 for an ARFTG Member and \$35.00 for a non-member. An additional \$9.00 is requested for airmail outside the USA.

EXCOM Elections

EXCOM elections were held at Monterey and officers elected were: Jim Taylor as President, Bill Pastori as Vice President, Gary Simpson as Treasurer, and Frank Mendoza as Secretary. Jim Rautio was newly elected and John Barr, Allen Rosenzweig and Ray Tucker were re-elected as EXCOM members.

Join ARFTG

We will be looking forward to discussing the latest in measurement automation and accuracy with you in Boston. ARFTG brings you the latest in RF, Microwave and Millimeter Wave analysis, design and measurement. State-of-the-art papers are presented twice a year. If you are involved in automated techniques, come and join your peers and keep current with our ever-evolving technology. For more information on ARFTG or future conferences, write: John Barr, Network Measurement Division, Hewlett-Packard, 1400 Fountaingrove Parkway, Santa Rosa, CA 95403.

*Selected as "Best Paper of the Conference."

Review of the 3rd Asia-Pacific Microwave Conference



by *Tsukasa Yoneyama*
*Research Institute of Electrical
Communication*
Tohoku University
*2-1-1 Katahira, Aoba-ku, Sendai 980
Japan*

The 3rd Asia-Pacific Microwave Conference (APMC '90) was held at the Prince Hotel and the World Import Mart in Sunshine City, Ikebukuro, Tokyo, from Tuesday, September 18, through Friday, September 21, last year. The conference was sponsored by the Institute of Electronics, Information and Communication Engineers (IEICE) of Japan, co-sponsored by IEEE MTT-S Tokyo Chapter, and supported by IEEE MTT-S and URSI. APMC '90 was the biggest microwave event held in Japan since the International Conference on Microwaves, Circuit Theory and Information Theory (ICMCI) held in Tokyo in 1964. Dr. Shigebumi Saito, Professor Emeritus, Tokyo University, served as the conference chairperson. MTT-S was represented by Prof. Tatsuo Itoh, University of Texas at Austin, and URSI by Prof. Takanori Okoshi, Tokyo University.

APMC was first held in India in 1986, then in China in 1988, and most recently in Japan last year, with the purpose of encouraging microwave research and development in the Asian-Pacific region. Volunteers from universities and microwave-related companies devoted themselves to arranging the conference for two years following the last APMC in Beijing in 1988. When the conference started, our concern was a big typhoon which was supposed to hit the mainland of Japan on the day of the banquet, the 20th, but luckily it passed the Tokyo area the previous night without disruption of the conference.

There were 631 invited and registered participants of which 530 were from Japan and 101 from overseas. There were 480 papers submitted from 31 countries, including not only Asian-Pacific countries but also countries in North America, Europe and Africa. Of these, 280 papers, including 10 invited papers, were accepted for aural presentation after careful selection by our Technical Program Committee referees. Five referees were responsible for reviewing each submitted paper. The technical program consisted of an opening keynote session, two invited sessions and 49 regular sessions which were scheduled in four parallel sessions under these categories:

- Keynote address: "Microwaves, past and 1990's" by Prof. Sogo Okamura, President of Tokyo Denki University. Invited sessions: 10 papers in 2 sessions.
- Microwave active devices: Microwave and millimeter wave monolithic technology (27 papers in 5 sessions), high-power and low-noise devices (11 in 2), active devices and circuits, (28 in 5), high-speed and high-frequency device technologies (10 in 2), opto-electronic techniques (7 in 1), microwave measurements for gigabit devices (5 in 1), TWT and gyrotron (4 in 1).
- Microwave passive devices: Microwave passive components (22 papers in 4 sessions), array antennas and microstrip antennas (31 in 5), microwave superconductivity (11 in 2), ferrite devices (5 in 1), NRD-guide technology (5 in 1).
- Microwave systems and applications: Microwave communi-

cation systems (12 papers in 2 sessions), microwave and millimeter wave systems (7 in 1), microwave medical/biological applications (11 in 2).

- Microwaves in general: Computer-aided design and numerical analysis (10 papers in 2 sessions), measurement theory and techniques (5 in 1), microwave field theory (11 in 2), planar circuits (10 in 2), waveguide theory (11 in 2), scattering and propagation (12 in 2), remote sensing (9 in 2), microwave circuit theory (5 in 1).

Three workshops were arranged on Friday afternoon to allow participants to catch up in the rapidly growing fields of heterojunction devices, transmission line analysis and circuit design methods for MMIC, and microwave superconductivity. In addition to selected Japanese experts, some distinguished speakers were invited from abroad. Even on the last afternoon of the conference, more than 250 participants joined one or more workshops. As a result, one room was overcrowded and extra chairs had to be carried in.

To our regret, about a quarter of the expected participants could not present their papers in session. The most probable reason for the absences was economic, but to my knowledge, at least one absence was due to the Gulf crisis and one other due to the typhoon.

The banquet, the biggest social event of the conference, was held on Thursday evening, September 20, after the typhoon had left without causing any trouble. There were about 350 guests that evening. Dr. Bun-ichi Oguchi, of Fujitsu Laboratories Ltd., offered the toast, and several distinguished guests, including Prof. Nobuaki Kumagai, President of Osaka University; Dr. Michiyuki Uenohara, of NEC; and three honorary life members of MTT-S, Theodore S. Saad, Kiyo Tomiyasu and Prof. Arthur A. Oliner gave congratulatory speeches. The guests enjoyed Japanese ancient musical dancing, maibayashi, and wind instrument music played by two voluntary groups from microwave-related companies. Foreign guests, more than the Japanese, seemed to be interested in maibayashi, but it must have been difficult for them to understand the real meaning because of the language barrier. The last piece played was the well-known "Waltzing Matilda," Australia being the site of APMC in 1992.

Another highlight of the conference was a technical exhibition which was held on the 4th and 7th floors of the World Import Mart in Sunshine City. More than 200 microwave and microwave-related companies displayed their products in the main pavilion on the 4th floor and in the U.S. pavilion on the 7th floor. Such a big exhibition could be realized by a joint effort with the U.S. Trade Center. The U.S. Trade Center left its annual microwave exhibition (Microwave U.S.A. '90) in the care of APMC '90. About 3500 attendees visited the exhibition rooms during the conference period.

At the international steering committee held on Wednesday evening, potential sites for future APMCs were proposed by members representing microwave-related organizations in Asian-Pacific countries. Australia was chosen as the host country for the next APMC. It will be held from August 11 to 13, 1992, in Adelaide, preceding the 14th International Electromagnetic Theory Symposium of URSI which will also be held in Sydney in the same country. To date, APMC has been held every two years, but after the conference in Australia in 1992, it should be possible to make this an annual event with the cooperation and efforts of the organizations and individuals concerned. We are looking forward to seeing you at APMCs at the following locations: Taiwan in 1993, Japan in 1994, Korea in 1995, India in 1996, Hong Kong in 1997 and Japan in 1998.

The 1223 page, hardcover proceedings of APMC '90 is available at a cost of ¥10,000 plus postage. Please write to: Prof. Tsukasa Yoneyama, Chairperson, Steering Committee, APMC '90, c/o Business Center for Academic Societies, Japan 3-23-1, Hongo, Bunkyo-ku, Tokyo 113, Japan.

Energy and Aerospace R&D Policy Committee



by William C. Brown, MTT-S
Representative to the Energy Policy
Committee and to the Aerospace R&D
Policy Committee of the United States
Activities Board

The purpose of the several committees of the IEEE U.S. Activities Board is to define the position of the IEEE with respect to national issues which involve electrical and electronic engineering and to make that position known to the Executive and Legislative branches of the government. The charters of the Energy Policy and Aerospace R&D Policy Committees involve several issues related to microwave technology.

Both of these committees have an interest in the Solar Power Satellite (SPS) Concept in which power is transmitted by microwave beam from a satellite extracting energy from the sun in geosynchronous orbit. The Energy Policy Committee is interested in it as an aid in solving our need for a pollution-free source of base load electrical power. The Aerospace R&D Policy Committee is interested in it for the microwave technology that is involved. There is some sentiment on both committees for a joint position statement on the SPS concept should it be included in legislation dealing with space or energy.

The Aerospace R&D Policy Committee is involved with critiquing present activities with respect to the development of space. They are evaluating the pros and cons for the construction of the Space Station. They also recognize the need for a better approach to the portion of the space transportation infrastructure involving transportation between low Earth orbit and geosynchronous orbit. Electric propulsion with its greatly decreased need for propellant mass could be that successful approach if there were a low mass means of providing the large amounts of electric energy needed for electric propulsion. They recognize that microwave power beamed from the Earth to a low mass rectenna that simultaneously captures the microwave beam and converts it into DC power may be the answer to this problem.

The Aerospace R&D Policy Committee has endorsed the ACTS or the Advanced Communications Technology Satellite, and its support may have been critical to enacting legislation in this area in recent years, because NASA itself has not consistently been in favor of it. It also endorses the NASP or National Aerospace Plane. The consensus of the committee on the Space Station is generally negative and reserved on President Bush's SEI or Space Exploration Initiative. The committee's agenda also includes a review of the activities directed toward ISY or the International Space Year, 1992.

MTT-S Chapter Meetings

Reporting Period:
9/25/90-1/7/91



by Joe Staudinger
MTT-S Chapter Records

ALBUQUERQUE (MTT/AP/EMC)

M. Widner, SNLA, "Launching Mass Into Space With Electromagnetic Coil Guns," 10/17/90. Attendance: 16.

CENTRAL NEW ENGLAND/BOSTON (MTT)

R. Webb, Webb Laboratories, "Limitations Intrinsic to Modern Microwave CAE Tools," 9/26/90. Attendance: 13.

R. Huguenin, Millitech Corp., "Millimeter Wave Imaging," 10/24/90. Attendance: 22.

K. M. Lau, University of MA, "High-Frequency and High-Speed Devices Fabricated by Organometallic Chemical Vapor Deposition," 11/28/90. Attendance: 13.

CHICAGO (MTT/AP)

J. D. Kotulski, Sandia National Labs., "Wavefront-Resonance Concepts in Transient Scattering," 2/12/90. Attendance: 9.

L. Stark, Ortel Corporation, "Broadband Fiber Optic Communication Links," 3/5/90. Attendance: 14.

S. L. Chuang, University of Illinois at Urbana, "Quantum Well Optoelectronics," 4/9/90. Attendance: 10.

R. E. Munson, Ball Aerospace Systems Division, "Microstrip Antennas: Principles and Applications," 5/21/90. Attendance: 24.

A. S. Brown, IEEE Video, "Gallium Indium Arsenide Heterostructure for Low Noise Amplification, High Speed Logic and Light Wave Detection," 7/30/90. Attendance: 7.

C. Bohn, Argonne National Laboratory, "Radio Frequency Properties and High-Power Applications of Low-T_c and High T_c Superconductors," 10/15/90. Attendance: 14.

W. Curtice, W. R. Curtice Consulting, "Nonlinear GaAs FET Modeling: A Mixture of Art and Science," 11/12/90. Attendance: 24.

CLEVELAND (MTT/ED/LEO)

Meeting, 11/19/90. Attendance: 9.

COLUMBUS (MTT/AP)

J. Whinnery, University of California, "Some Relations Between Microwaves and Optics," 9/19/90. Attendance: 47.

W. D. Burnside, Ohio State University, "Stealth Pushes Radar Measurement Frontiers," 10/16/90. Attendance: 131.

DALLAS (MTT)

D. P. Neikirk, University of Texas, "Microwave and Millimeter-Wave Oscillations Using Quantum-Well Diodes," 9/27/90. Attendance: 15.

D. Seymour, Texas Instruments, "The PIN Diode and Its Microwave Applications," 10/25/90. Attendance: 29.

- J. B. Y. Tsui, Wright Research Center, "Electronic Warfare (EW) Receivers," 11/15/90. Attendance: 74.
 M. Engelson, Tektronix, "In Search of Ghosts—The Modern Spectrum Analyzer," 12/9/90. Attendance: 19.

DENVER-BOULDER (MTT/AP/GRS)

- D. Phang, University of Colorado, "Electromagnetic Modeling of Passive MIMMIC Components," 9/20/90. Attendance: 30.
 W. R. Curtice, W. R. Curtice Consulting, "Nonlinear GaAs and FET Modeling: A Mixture of Art and Science," 10/18/90. Attendance: 35.
 W. Crosswell, Harris Corp., "Spacecraft and Aircraft Antennas," 11/15/90. Attendance: 60.

FINLAND (MTT/AP)

- D. Chang, University of Colorado, "Computer-Aided Design of Microstrip Antennas and Arrays," 8/23/90. Attendance: 24.
 V. Rizzoli, University of Bologna, "Simulation and Design of Nonlinear Microwave Circuits," 10/8/90. Attendance: 36.

FRANCE (MTT)

- J. Magarshack, Thomson CSF, "MMIC Activities in Europe," 9/6/90. Attendance: 18.

HUNGARY (MTT/AP/COM/ED)

- F. Ivanek, Communications Research, "Topics in Digital Communications," 11/19/90. Attendance: 19.

MILWAUKEE (MTT/AP/ED/IM)

- G. Pan, University of Wisconsin, "A Full-Wave Solution to Microstrip Lines," 11/14/90. Attendance: 19.

NORTH JERSEY COAST (MTT/ED/LEO)

- S. Habiby, Bell Core, "The Terabit Switch," 9/26/90. Attendance: 11.
 J. Jewell, AT&T Bell Laboratories, "Surface-Emitting Lasers for Optical Micro-Communications," 10/23/90. Attendance: 11.
 C. J. Cotton, Bell Core, "Computer Communications at Gigabit Speeds," 11/27/90. Attendance: 23.

NEW YORK/LONG ISLAND (MTT)

- D. Zwillinger, Zwillinger, Sousa and Associates, "Chaos: A Tutorial," 4/24/90. Attendance: 54.
 W. Curtice, W. R. Curtice Consulting, "Nonlinear GaAs FET Modeling: A Mixture of Art and Science," 5/16/90. Attendance: 15.
 D. J. Whinnery, University of California, "Some Relations Between Microwaves and Optics," 10/17/90. Attendance: 42.
 F. J. Winter, AIL Systems Inc., "Recent Advances in Multiport Network Theory," 12/10/90. Attendance: 20.

NEW JERSEY (MTT/AP)

- F. Schwering, Rutgers University and New Jersey Institute of Technology, "Millimeter Wave Antennas," 1/31/90. Attendance: 34.
 E. Schanda, Institute of Applied Physics, "Remote Sensing With Microwaves and Millimeter-Waves," 2/19/90. Attendance: 17.
 R. Knerr, AT&T Bell Laboratories, "Lightwave Communications," 4/5/90. Attendance: 62.
 U. Rhode, Compact Software, "Nonlinear Noise Model for MESFET," 9/6/90. Attendance: 53.
 W. Curtice, W. R. Curtice Consulting, "Nonlinear FET Modeling," 12/6/90. Attendance: 17.

ORLANDO (MTT/AP)

- V. Tripathi, University of Central Florida, "Computational Methods in MMIC Planar and Quasi-Planar Structures," 9/20/90. Attendance: 14.

PHILADELPHIA (MTT/AP)

- B. Wells, Science Applications International Corporation, "An Introduction to Wavelets," 9/26/90. Attendance: 25.
 A. S. Daryoush, Drexel University, "Microwave Photonics," 10/29/90. Attendance: 9.
 A. R. Ochadlick, Naval Air Development Center, "Synthetic Aperture Radar (SAR) Imagery of the Ocean," 11/29/90. Attendance: 19.

PHOENIX (MTT/AP/ED/EMC/LEO)

- L. Akers, Arizona State University, "An Overview of the Center for Solid State Electronics Research," 9/27/90. Attendance: 39.
 E. El-Sharawy, Arizona State University, "Planar Microwave Phase Shifter Technology," 10/11/90. Attendance: 18.
 W. Curtice, W. R. Curtice Consulting, "Nonlinear GaAs FET Modeling: A Mixture of Art and Science," 10/17/90. Attendance: 26.
 R. O. Grondin, Arizona State University, "Single Electronics: Science Fiction or Science Fact?," 11/15/90. Attendance: 21.
 A. Taflove, Northwestern University, "Supercomputing Computational Electromagnetics," 11/29/90. Attendance: 27.

SAN FERNANDO VALLEY (MTT)

- R. Wessen, JET Propulsion Laboratory, "The Voyager Grand Tour Mission," 9/13/90. Attendance: 41.

SAO PAULO (MTT)

- L. G. Martinez, Maprz, "Innovations on Antennae Brazilian Technology," 4/18/90. Attendance: 22.
 J. Whinnery, University of California, "Interrelations Between Microwave and Optics," 8/1/90. Attendance: 21.
 J. Whinnery, University of California, "Generation and Use of Optical Short Pulses," 8/2/90. Attendance: 14.

SOUTH AFRICA (MTT/AP)

- J. C. Olivier, CSIK, "The Finite Difference Time-Domain Analysis of Multiport Waveguide Junctions and Discontinuities"; D. Van Rensburg, LGI, "Improvements in the Numerical Analysis of Conducting Thin-Wire Radiators," 10/30/90. Attendance: 10.
 E. Barnard, University of Pretoria, "Neural Networks: An Introduction"; J. Jouberty, University of Pretoria, "The Analysis of Radiating Slots in the Broad Wall of a Rectangular Waveguide Inhomogeneously Loaded With a Dielectric Slab," 11/21/90. Attendance: 19.

SWEDEN (MTT/AP)

- D. Chang, University of Colorado, "Computer-Aided Design of Microstrip Antennas and Arrays"; S. Rengarajan, California State University, "Recent Developments in Waveguide-Fed Slot Arrays," 8/22/90. Attendance: 22.
 R. Trew, North Carolina State University, "MESFET Models for Nonlinear Microwave CAD," 9/27/90. Attendance: 18.
 V. Rizzoli, University of Bologna, "Simulation and Design of Nonlinear Microwave Circuits," 10/10/90. Attendance: 16.

TOKYO (MTT)

- H. Ogawa and 3 other members, ATR, "A Report on the 1990 IEEE MTT-S International Microwave Symposium Workshop," 7/27/90. Attendance: 29.

Y. Ito and 5 members, "A Report on the 1990 IEEE MTT-S International Microwave Conference," 8/24/90. Attendance: 62.

A. A. Oliner, Polytechnic University, "Leaky Waves: Basic Properties and Applications to Microwave and Optics," 10/6/90. Attendance: 50.

UNITED KINGDOM/IRELAND (MTT/ED)

B. Jackson, Thorn EMI, "RADAR Signature Control Through Measurement and Prediction," 12/19/90. Attendance: 20.

WASHINGTON/NORTHERN VIRGINIA (MTT)

D. Nicholson, Engineering Research Associates, "Spread Spectrum Theory Overview," 10/9/90. Attendance: 115.

E. Palo, Mitre Corporation, "Spread Spectrum Hardware Architecture Overview," 11/13/90. Attendance: 85.

R. McMillian, Georgia Tech Research Institute, "Atmospheric Transmission Phenomena," 12/11/90. Attendance: 65.

YUGOSLAVIA (MTT)

V. Rizzoli, University of Bologna, "Simulation and Design of Nonlinear Microwave Circuits," 9/18/90. Attendance: 55.

Workshops, Symposia, Clinics & Social Events

Reporting Period:
9/24/90-1/7/91

CHICAGO (MTT/AP)

Motorola Microwave Facility Tour, 9/10/90. Attendance: 32.
Annual Planning Meeting, 10/2/90. Attendance: 5.

DALLAS (MTT)

Microwave Active Circuits and GaAs Microwave Transistors, 9/13/90. Attendance: 25. S. E. Sussman-Fort, State University of New York, "A Realization of a GaAs FET Microwave Filter"; C. Y. Chen, T. J. Shieh, R. L. Carter, University of Texas at Arlington, "A Submicron Self-Aligned Gate GaAs MESFET Processing Technique for MMIC Device Fabrication"; S. Goldman, E-Systems, "Optimum PLL Design for Low Phase Noise Performance"; B. Frenslley, University of Texas at Dallas, "GaAs Physics"; R. J. Trew, North Carolina State University, "GaAs MESFET Modelling"; B. Bayraktaroglu, Texas Instruments Central Research Lab., "Heterojunction Bipolar Transistors."

Half day seminar on nonlinear circuits, 11/9/90. Attendance: 62. S. A. Mass, UCLA, "Nonlinear Circuit Analysis With Application to Power Amplifier and Mixer Design."

FRANCE (MTT)

Workshop on Microwave Measurement, 11/22-23/90. Attendance: 80. 34 papers presented.

HUNGARY (MTT/AP/COMED)

Seminar on Optical Microwave Interaction, 9/7/90. Attendance: 24. P. R. Herczfeld, Drexel University, "Optical-Microwave Interactions"; A. Baranyi, TKI, P. Gottwald, Budapest Technical University, "Microwave MESFET Modeling for Optical Synchronization"; T. Bercei, TKI, "Linearity Problems in Modulation and Detection of Optical Waves"; B. Szentpali, MFKI, "High Speed Optical Switches"; V. V.

Kontop, Institute for Radiophysics, "Solutions in Irregular Fibers"; K. Kazi, MFKI, "Broadband, Lossy Model of Diode Packages: Method for Exact Evaluation of Active Chip Parameters"; M. H. Rahnavard, Shiraz University, "Excess Carrier in Moving Gaussian Spot Illuminated Semiconductor Panel and Its Use in Millimeter-Wave Image Converter"; I. Frigyes, T. Bercei, I. Kasa, F. Mernyei, B. Molnar, I. Pacher, V. Geleji, Budapest Technical University, "Direct Optical Tuning of Microwave Signals—Research Project at BME-MHT"; I. Kasa, I. Frigyes, A. Hilt, Budapest Technical University, "Transmission Experiments on Digitally Modulated Microwaves via Lightwaves"; M. Izutsu, Osaka University, "Microwave Application of Integrated Optics"; B. N. Biswas, Burdwan University, "Optical Impedance and Efficient Frequency Control of Impatt Oscillators at Microwaves"; S. Takacs, Budapest Technical University, "Estimation for the Transmission Capacity of a Lossy Single-Mode Optical Fiber Communication Link."

T. Itoh, S. Adam, K. Richter, A. Vander Vorst, I. Frigyes, "Official Founding of the Chapter," 9/12/90. Attendance: 20.

NEW JERSEY COAST (MTT/ED/LEO)

Planning meeting for 1990-1991 Speakers Schedule and Budget, 9/4/90. Attendance: 4.

NEW YORK/LONG ISLAND (MTT)

1990 IEEE Long Island MTT Symposium including 26 exhibitors, 6/6/90. Attendance: 136. J. Pierro, "Introductory Remarks"; F. Lanza, Loral Corporation, "Keynote Address"; J. Sunkes, Wright Patterson AFB, "Systems Engineering Process—Electronic Countermeasures"; J. Montgomery, ElectroniCast, "Trends in Microwave Components for the 1990's"; C. Huang, Anadigics, "GaAs ICs for Satellite and Fiber Optic Receivers"; J. White, Waveteck, Inc., "Peak Power Measurement Technology"; S. Padmanabham, Miteq Inc., "Very Low Noise Phase Locked DRO"; P. Kapetanic, Wiltron, "Vector Pulse Profiling Using Carrier Spectral Line With 29nS Resolution"; J. Cuthbertson, Ball/Efratom Div., "Advances in Time and Frequency Management in Microwave and Rf Systems"; R. Gilmore, Qualcomm Inc., "Hybrid PLL/DDS Frequency Synthesizers"; A. Rosenzweig, Ferretec, "Extending the Dynamic Range of Scaler Network Analyzer Measurements"; Z. Cendes, Ansoft Corp., "High Frequency Structure Simulator"; U. Rhode, Compact Software, "A New Approach to Systems Simulation."

NORTH JERSEY (MTT/AP)

OptoElectronics Seminar, 2/7/90. Attendance: 165.

OptoElectronics Seminar, 3/7/90. Attendance: 125.

Symposium and Mini-Show, 11/8/90. R. Schineller, T. Pospishil, ITT, "The Phase I MMIC Program"; attendance: 53. B. Perlman, U.S. Army, "Pursuit of a Hardware Description"; L. Carmichael, U.S. Army, "Language for Analog/Microwave," attendance: 49. Minishow with 36 exhibitors, attendance: 337.

SAO PAULO (MTT)

Various speakers, "First Brazilian Seminar on Microwave Software," 2/13/90. Attendance: 19.

Various speakers, "First Seminar on Microwave Automated Measurements," 10/18/90. Attendance: 35.

TOKYO (MTT)

The 3rd Asia-Pacific Microwave Conference—APMC '90, 9/18-21/90. Attendance: 586. The conference included 279 papers and three workshops.

Call for Nominations for 1992 MTT-S Awards

Microwave Career Award

Description of the Award:

Prize: Certificate, a plaque and \$2,000.

Eligibility: A career of meritorious achievement and outstanding technical contribution by an individual in the field of microwave theory and techniques; individual must be a member of IEEE.

Basis for Judging: Publication in technical journals, presentation of lectures, contributions to the advancement of microwave technology, and other technical contributions considered in conjunction with any or all of these areas of contribution; nominations are considered annually; award is made aperiodically.

Presentation (when presented): At the annual MTT-S Symposium. (Note: Travel allowance of up to \$1,000 is granted on a need basis for travel to the Symposium.)

Distinguished Service Award

Description of the Award:

Prize: Plaque and certificate.

Eligibility: Significant contributions and outstanding service to the Microwave Theory and Techniques Society and the microwave profession over a sustained period of time.

Basis for Judging: Service to AdCom and IEEE. Nominations considered aperiodically and awards made aperiodically.

Presentation (when presented): At annual MTT-S Symposium.

Microwave Application Award

Description of the Award:

Prize: Certificate and \$1,000.

Eligibility: Outstanding application of microwave theory and techniques by an individual to create a new device, component or technique; novel use of a device or component; or any combination of the above.

Basis for Judging: The most outstanding application of microwave theory and techniques by an individual; nominations must be submitted by a member of the Society; nominations are considered annually; award is aperiodic.

Presentation (when presented): At annual MTT-S Symposium.

Microwave Prize

Description of the Award:

Prize: Plaque and certificate.

Eligibility: Authors of papers making significant contribution to the MTT-S field of interest published in any IEEE publication during the year ending June 30th preceding the award; the author need not be a member of IEEE.

Basis for Judging: The most significant contribution in the previous year in the field of interest of the MTT Society.

Presentation (when presented): At annual MTT-S Symposium.

Pioneer Award

Description of the Award:

Prize: Certificate, a plaque and \$1,000; feature publication in *MTT Transactions* and *Newsletter*. If a team is named recipient, each shall receive a plaque and the honorarium shall be shared.

Eligibility: Publication of contribution in an archival journal, an individual or team not exceeding three persons. Deceased persons are ineligible for nomination. Preference may be given to IEEE members.

Basis for Judging: Proposed award is to recognize an individual(s) who has made a major, lasting contribution in the

field of interest of MTT-S at least 20 years prior to the year of the award.

Presentation (when presented): At the annual MTT-S Symposium. Upon request, travel and living expenses for the recipient for attendance at the presentation ceremony shall be reimbursed.

Please send the completed nomination form to:

Dr. L. N. Medgyesi-Mitschang
McDonnell Douglas Research Laboratories
Bldg. 110, Mail Code 111-1041
8901 Airport Road
Berkeley, MO 63134 U.S.A.

1992 IEEE Microwave Theory and Techniques Society Fellowships and Grants-in-Aid

Graduate Fellowships

- Several \$5,000 fellowship awards each year.
 - For graduate research studies in microwave engineering on a full-time basis.
 - Applicants must have attained high academic achievement in engineering or physics.
 - Award can be granted *in addition* to any other support received by student.
 - Award cannot be used for equipment purchase, travel, supplies, etc.
 - Award made to institution for support of named student.
 - Faculty supervisor must be MTT-S member.
- Application deadline: 21 October 1991

Educational Grants-in-Aid

- For individual members of MTT-S.
 - Number and amount to be based on proposals submitted, proposed activity, financial justification, and Society budget.
 - Applicant must be MTT-S member of 5 years standing.
 - Applicant must be a full-time employee of a degree granting institution of higher learning or a not-for-profit research institution.
 - Emphasis is on supporting junior faculty members.
 - Award made to institution for support of named individual research activity (i.e., faculty member, etc.).
 - Award may be used for equipment, travel, supplies, or individual use, directly related to a clearly defined microwave activity.
 - Funds cannot be carried over into second year.
- Application deadline: 12 November 1991

For applications for the Fellowships and Grants-in-Aid contact:

Dr. Jorg E. Raue
Chairman, MTT-S Educational Awards Committee
TRW, Electronics Systems Group, R5/1291
One Space Park
Redondo Beach, CA 90278
(213) 813-8224

Requests for application materials must be received no later than 30 September 1991.

Workshop:
“Technology of Heterostructure Devices”

July 14-16, 1991

Reisenburg near Ulm, FRG

Please contact:

Prof. Dr.-Ing. E. Kohn

University of Ulm

P.O. Box 4066, D-7900 Ulm/FRG

Tel.: +49 (731) 176-3050, Fax: +49 (731) 5413

Workshop:

**“CAD Oriented Numerical Techniques for the Analysis
of Microwave and mm-Wave Transmission Line
Discontinuities and Junctions”**

September 13, 1991

Stuttgart/FRG

Please contact:

Prof. Dr.-Ing. F. Arndt

University of Bremen

P.O. Box 33 04 40, D-2800 Bremen/FRG

Tel.: +49 (421) 218-3515, Fax: +49 (421) 218-3601

or

Dr.-Ing. W. Heinrich

Technical University of Darmstadt

Merckstr. 25, D-6100 Darmstadt/FRG

Tel.: +49 (6151) 16-2162, Fax: +49 (6151) 16-4367

Workshop:

“Microwave Measurement Techniques”

October 10-11, 1991

Ratingen (near Düsseldorf), FRG

Please contact:

Dr.-Ing. R. H. Jansen

Bürohaus am See

AmBrüll 17, D-4030 Ratingen 1/FRG

Tel.: +49 (2102) 83095, Fax: +49 (2102) 842391

Antenna Measurement Techniques Association
Workshop
Characterization of Ranges for Antenna
and/or RCS Measurements
28 June 1991

University of Western Ontario London, Ontario, Canada

Contact:

Steve Brumley, AMTA Workshop Coordinator
6301 W. Ivanhoe Street
Chandler, Arizona 85226
(602) 961-0910 • Fax (602) 940-1401

Antenna Measurement Techniques Association
Symposium

The annual AMTA symposium will be
October 7-11, 1991

at the

Clarion Harvest Hotel
Boulder, Colorado

Deadline for submission of abstracts is May 10

Information can be obtained by contacting:

Sharon Sandera
1991 AMTA Symposium
c/o N.I.S.T., Mailstop 813.05
Boulder, Colorado 80303-3328
(303) 497-3302

Registration forms will be mailed in June
and registration will continue until the symposium in October

Call for Papers for Microwave Technology Symposium (ISRAMT '91)

The 3rd International Symposium on Recent Advances in Microwave Technology (ISRAMT '91) sponsored by the University of Nevada, Reno, IEEE Northern Nevada Section and Desert Research Institute, Reno, NV, is scheduled from **August 18-21, 1991 (Revised Dates)** in Reno, Nevada, U.S.A. The symposium will cover all the topics in Microwave Technology and Its Applications including:

- Components & Circuits
- Antenna & Radar
- MICs & mm-ICs
- Remote Sensing
- Biological Effects & Other Applications
- Communication Systems
- CAD Techniques
- Propagation & Measurements
- Electro-Optics
- Microwave/mm-wave Optical Technology
- Microwave Superconductivity and Microwave Education

Exhibits of Industrial Products and Workshops are also planned. One original and 3 copies of the 4-page manuscript prepared according to the instructions (sent on request) are required by **May 10, 1991**. The working language of the symposium will be English. For additional information regarding manuscripts, industrial exhibits and workshops, please contact:

Banmali Rawat, Co-Chairman
Technical Program Committee
Electrical Engineering Department
University of Nevada, Reno
Reno, NV 89557-0030 U.S.A.
Telephone: (702) 784-6927, Fax: (702) 784-1300

IEEE Transactions on Applied Superconductivity

A new journal focused on electrical and electronic applications
of superconductivity and related materials technology.

PUBLISHED QUARTERLY
Inaugural issue: March 1991

The *IEEE Transactions on Applied Superconductivity* is published by the IEEE Superconductivity Committee on behalf of the following societies: Communications; Components, Hybrids and Manufacturing Technology; Dielectrics and Electrical Insulation; Electron Devices; Instrumentation and Measurements; Magnetics; Microwave Theory and Techniques; Power Electronics; Power Engineering; and Ultrasonics, Ferroelectrics and Frequency Control.

Subscription Information

Members of sponsoring IEEE societies\$10/year

Nonmembers\$80/year

For More Information:

IEEE Service Center
Piscataway, NJ 08855-1331 U.S.A.
Telephone: 1-800-678-4333

First Announcement
GaAs '92
European Gallium Arsenide
and related III-V compounds
Applications Symposium

After two decades of basic research, process development and the stabilization of manufacturing processes, microwave/mm-wave analog ICs (MMICs) and related high speed digital circuits on gallium arsenide and other III-V compounds are now entering a broad range of applications. Stable MESFET and HEMT technologies are available for applications ranging from very low noise ICs at high mm-wave frequencies to discrete devices with several tens of Watts of CS power at a few GHz. In addition, the maturing of HBT technology is showing great promise for power MMICs. Broadband amplification covering the range of 5-100 GHz in one step has been demonstrated recently and monolithic integrated circuits extending to 300 GHz appear feasible today.

In parallel to mature technologies, high volume markets are becoming visible increasingly. Particularly in Europe, there are now exciting opportunities for applications in such areas as mobile telephone, communication networks, direct broadcasting from satellites (DBS) and in the extremely important market of automobiles and transport systems. A number of well-established GaAs foundries are giving circuit designers all over Europe the access to stable and statistically verified manufacturing processes. In view of this situation, the GaAs Applications Symposium is intended to provide a European forum for the exchange of information in the rapidly growing field of applications of gallium arsenide and other III-V compound semiconductors.

The Symposium is strictly applications-oriented and will seek to avoid overlap with workshops existing already in the field of III-V semiconductor materials and device technology. Subject areas concerned with the design, component and systems applications, manufacturing, testing and packaging of GaAs and related monolithic ICs are of particular interest for the Symposium. In more detail, topics of interest include the following areas:

- GaAs MESFET, HEMT, HBT and related ICs
- Device Applications, Circuits and Subsystems
- Technology-Related CAD Techniques
- Manufacturing Aspects, Yield, Statistics
- Testing and Packaging
- Reliability and Fault Diagnosis
- Integrated Optoelectronic Circuits

After agreement has been obtained with several European groups and a first GaAs Applications Symposium was held successfully at Rome in April 1990, it is time to make this Symposium a regular European event. Its conduction is planned as a biannual conference starting 1992 and continuing in 1994, 1996, etc., at different places in Europe. It will alternate with the International Workshop on GaAs in Telecommunications organized biannually by Telettra, Italy, since 1987, and an Italian GaAs conference in the odd years with a more restricted scope and national character.

The GaAs '92 is planned for late spring 1992 at Cologne, West Germany, and will be organized by the Germany IEEE MTT/AP chapter with cooperative sponsorship by the IEE Microwave Theory and Techniques Society. A first call for papers will be published in May 1991. For further information please contact one of the two addresses given below:

Network Ltd.

GaAs '92 Conference Bureau
Wilhelm-Suhr-Str. 14
W-3055 Hagenburg
Tel.: +49-5033-7057
Fax: +49-5033-7944

Prof. Dr. Rolf H. Jansen
GaAs '92 Conference Chairman
Bürohaus am See, Am Brüll 17
W-4030 Ratingen 1
Tel.: +49-2102-83095
Fax: +49-2102-842391

LEOS Summer Topical Meeting
on
**Optical Millimeter-Wave Interactions:
Measurements, Generation, Transmission
and Control**

July 24 - 26 1991
Sheraton Newport Beach, Newport Beach, California

Scope

This meeting will focus on the expanding role of optical lasers and electro-optics in millimeter-wave applications. Use of picosecond testing has become the major technique for evaluating the newest advances in high frequency semiconducting devices including FETs, HEMTs, and Heterojunction Bipolar transistors. Recently these laser based, pulsed systems have also been used to generate millimeter waves and open up new forms of spectroscopy. Continuous wave lasers, in conjunction with mixing and high frequency modulators, have established an important role in the transmission and control of millimeter wave signals. In addition to reviewing the current technology, the meeting will examine the next stage in the development of optical millimeter-wave systems.

Invited Speakers

D. Auston
Columbia University

K. Chang
Texas A&M University

A. Yariv
California Institute of Technology

B. Hendrickson
Rome Laboratory

S. Y. Wang
Hewlett-Packard Labs

X. C. Zhang
Columbia University

Conference Committee

Topical Co-Chairs:

Harold Fetterman
University of California

G. Arjavalingam
IBM, T. J. Watson Research Center

Program Committee:

David Auston
Columbia University

Kul Bhasin
NASA Lewis Research Center

T. Itoh
University of Texas at Austin

Chi-Hsiang Lee
University of Maryland

George Simonis
Harry Diamond Laboratory

Optical Millimeter-Wave Interactions is the second of four meetings in the Summer'91 Topical Meetings series. All four meetings, from July 22 - August 2, 1991, will be held at the Newport Beach Sheraton in Newport Beach, California. To request a complete Call for Papers, listing abstract submission information and titles of invited talks, or to be placed on the mailing list, contact:



IEEE/LEOS, 445 Hoes Lane, P.O. Box 1331, Piscataway, NJ 08855-1331
phone (908) 562-3896 or fax (908) 562-1571.



Paper submission deadline is **April 1, 1991.**

Sponsored by the IEEE Lasers and Electro-Optics Society and in cooperation with the IEEE Microwave Theory and Techniques Society and the Optical Society of America.

**IF YOU WERE UNABLE TO ATTEND
A RECENT CONFERENCE**

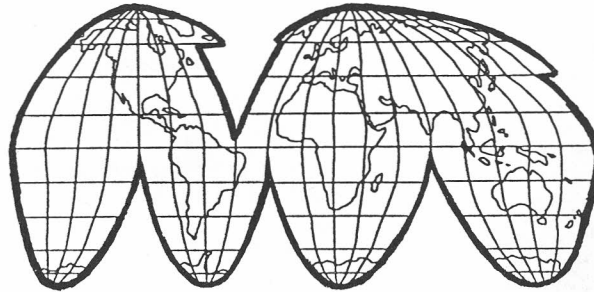

YOU CAN STILL ORDER THE CONFERENCE PROCEEDINGS

TO ORDER OR TO REQUEST A FREE CATALOG

TOLL-FREE IN THE U.S. AND CANADA CALL
1-800-678-IEEE

IN OTHER COUNTRIES CALL
(908) 981-0060

FAX (908) 981-9667

OR WRITE
IEEE CUSTOMER SERVICE DEPARTMENT
445 HOES LANE, PO BOX 1331
PISCATAWAY, NJ 08855-1331 U.S.A.

IN EUROPE, THE MIDDLE EAST, AFRICA OR THE USSR
CONTACT THE NEW BRUSSELS OFFICE

CALL 32.2.770.22.42.

FAX 32.2.770.85.05

OR WRITE
IEEE TAB OFFICE
13, AVENUE DE L'AQUILON
B-1200 BRUSSELS BELGIUM



IEEE

A SERVICE OF IEEE TECHNICAL ACTIVITIES DEPARTMENT

Editor's Notes

(continued from page 2)

every three years. With this interval, the reports ought to cover a good range of activities and to show a progressive level of change. A shorter interval would probably have less depth and may not truly indicate the changes within the committee's scope. Also, we plan to have other feature articles to focus upon other areas of the MTT Society such as the article by Steve Maas in this issue on the *MTT-S Transactions*.

I've appointed an Associate Editor, David Zimmerman, to assist me in the publishing cycle. David served as vice-chairman of the Technical Program Committee for the 1990 IMS held in Dallas. I appreciate his willingness to help me in future issues and to bring some order to my haphazard way of doing things. Our addresses are listed in the 1991 MTT-S Directory included in this issue. I urge you to write John Eisenberg, Rolf Jansen, David Zimmerman, or me if you have any suggestions for improving the *Newsletter* or if you are interested in publishing an article.

Pete Staecker and his crew for the 1991 International Microwave symposium have been working hard to prepare for the June event. The reports in this issue highlight the many activities we should anticipate this year in Boston. Boston is a very special city with a unique charm and beauty, with something for all to enjoy. The Boston influence over the years has been far-reaching and revolutionary, particularly for the field of microwave technology. The 1991 IMS promises to be a rewarding experience, so please make your plans to join us.

Feature Articles for the MTT Newsletter



by John Eisenberg

The MTT Newsletter staff is interested in obtaining feature articles dealing with current topics in the technical and professional areas of interest to MTT members. These articles should provide members with a general understanding of the topic and its significance in current and future activities in the microwave field. I would like to emphasize, however, that these special articles should cover topics in a broad, general sense. Specific design techniques and applications will be covered in the papers appearing at the MTT Symposium and in the *Transactions*.

If you know of a topic that is current and/or you are willing to contribute an article to the Newsletter, please contact:

John Eisenberg
25 Parson Way
Los Altos, CA 94022
(415) 941-7426



THE INSTITUTE OF
ELECTRICAL AND
ELECTRONICS
ENGINEERS, INC.

445 Hoes Lane
P.O. Box 1331
Piscataway, NJ 08855-1331

Non-Profit Organization
U.S. Postage
PAID
PERMIT NO. 52
PISCATAWAY, NJ

Third Class